

Porcelain Mosaic Stone Grés cérame Mosaïque Pierre
Porcellanato Mosaico Pietra Porcelain Mosaic Stone
Керамогранит Мозаика Камень Porcelánico Mosaico Piedra
Porcelain Mosaik Stein Керамогранит Мозаика Камень
Grés cérame Mosaïque Pierre Porcelain Mosaik Stein
Pietra Porcellanato Mosaico Pietra Porcelain Mosaic Stone
Porcelánico Mosaico Piedra Porcellanato Mosaico Pietra
Керамогранит Мозаика Камень Porcelánico Mosaico
Grés cérame Mosaïque Pierre Porcelain Mosaik Stein
Porcelain Mosaic Stone Grés cérame Mosaïque Pierre
Porcellanato Mosaico Pietra Porcelain Mosaic Stone

CATÁLOGO GENERAL 2016







Quienes somos

INTERMATEX Grupo es en la actualidad el resultado de un esfuerzo colectivo que comenzó en 1988 cuando D. Fidel Gil y Dña. Virginia Miralles fundaron la empresa matriz Matex Spain.

Desde entonces, dentro de un proceso de adaptación continua a las demandas del mercado y una evolución constante en la línea de innovación y desarrollo, se han ido perfilando las líneas de producto que hoy en día identifican a **INTERMATEX** Grupo en todos los países en los que está presente. Esta evolución constante ha supuesto, por encima de todo, alcanzar el grado de reconocimiento y satisfacción que la inmensa mayoría de clientes nos ha transmitido. Dentro de esta dinámica de crecimiento y expansión, **INTERMATEX** Grupo ha desarrollado dos marcas comerciales para diferenciar sus dos líneas de producto más vanguardistas y exclusivas en cuanto a diseño, creatividad e innovación.

INTERMATEX es una referencia consolidada a nivel mundial en todo lo concerniente al mosaico. Son más de 50 países en los que esta línea de producto está presente a través de multitud de clientes.

ESSENTIA es nuestra recién estrenada marca para dar cabida a desarrollos y diseños que combinen de un modo innovador y pionero un entorno clásico de la materia prima empleada transformada en un concepto vanguardista y moderno gracias a la combinación de estéticas y desarrollos tecnológicos novedosos.

Agradecemos sinceramente a todos nuestros clientes y colaboradores la fidelidad y apoyo que a lo largo de estos años nos han mostrado y les invitamos a que participen con nosotros en los apasionantes retos que tenemos por delante.



About us

INTERMATEX Group, nowadays, is the result of a collective effort that began in 1988 when D. Fidel Gil and Da. Virginia Miralles founded the parent company Matex Spain.

Since then, through a continuous adaptation process of market demands and a constant evolution in the innovation and development trends, have been settled product lines that today are the identity of **INTERMATEX** Group in all countries in which is present. This constant evolution has meant, above all, achieving the degree of appreciation and satisfaction that the vast majority of customers have transmitted us.

Within this dynamic growth and expansion, **INTERMATEX** Group has developed two brands to differentiate its two most advanced product lines and unique in design, creativity and innovation.

INTERMATEX is a reference established worldwide in all matters concerning the mosaic. It is more than 50 countries in which this product line is present across many clients.

ESSENTIA is our newly brand to accommodate developments and designs that combine in an innovative and pioneering way the classical settings of the raw materials by means of processing into a modern concept through a combination of innovative aesthetic and technological developments.

We sincerely thank all our customers and partners the fidelity and support they have shown us over the years and we invite you to join us in the exciting challenges ahead.



Intermatex Grupo obtuvo en Enero de 2012 las certificaciones ISO 9001 (Sistema de Gestión de la Calidad) e ISO 14001 (Sistema de Gestión Ambiental) como culminación a un proceso de adaptación a los estándares actuales. De este modo, la empresa mantiene su firme apuesta por la calidad, la fiabilidad y la atención al cliente, como los principales argumentos que van a seguir definiendo nuestra idea de negocio. A todos los clientes y proveedores de Intermatex Grupo, así como de sus empresas Intermatex SL y Matex Spain SL, queremos agradecer su colaboración activa en este logro gracias a sus positivas propuestas de mejora.



Intermatex Grupo, in January 2012, achieved the ISO 9001 (Quality Management System) and ISO 14001 (Environmental Management System) as the culmination of a process of adaptation to current standards. Thus, the company maintains its strong commitment to quality, reliability and customer service as the main arguments that will further define our business idea.



Índice / Index

MOSAICO / MOSAIC



Carnaval	8
Vintage	16
Elements	22
Tour	24
Living	26
Kroma	32
Mojave	34
Marrakech	37
Classic	38
Faenza	40
Fashion	42
Minimal	44
Polar	45
Exclusive	46
Frame	47
Kaos	49
Royal	50
Quartz	52
Stripes	58
Imperium	60
Artist	62
Safari	64
Elegance	70
Reflections	71
Diamond	71
Luxury	71
Nácar	72
Myka	74
Planet	76
Lagos	78
Kubica	84
Glass	87
Forest	87
Mármol	87
Ares	87
Catí	87
Perla	88

ESSENTIA



Mosaico / Mosaic	
Matrix	90
City	92
Cubik	94
Piedra Natural / Natural Stone	
Petra	96

PORCELÁNICO / PORCELAIN



Cementi	112
Strato	122
Alpes	126
Loft.....	132
Domus	136
Lux.....	140
Montblanc.....	141
Teide.....	142
Teknia	144
Artic	145
Artic 3D	145
Quartz Artic 3D.....	145
Kenya	147
Kenya 3D.....	147
Quartz Kenya 3D.....	147
Marmi	148
Simat.....	149
Layer.....	150
Capri.....	151
Módena	153

ACC. BAÑO / BATHROOM ACC.



Acqua.....	154
Acqua.....	155
Tuning.....	157

INF. TÉCNICA / TECHNICAL INFO



Especificaciones Técnicas / Technical Specifications.....	158
Promoción / Promotion	159
Consejos de colocación / Recommendations for laying.....	164

Índice alfabético Alphabetic index



SERIE	PÁG.	MOSAIC	ESSENTIA	PORCELAIN	ACCESORIOS DE BAÑO
Acqua	155				
Alpes	126				
Ares	87				
Artic	145				
Artic 3D	145				
Artist	62				
Capri	151				
Carnaval	8				
Catí	87				
Cementi	112				
City	92				
Classic	38				
Cubik	94				
Diamond	71				
Domus	136				
Elements	22				
Faenza	40				
Fashion	42				
Forest	87				
Frame	47				
Glass	87				
Imperium	60				
Kaos	49				
Kenya	147				
Kenya 3D	147				
Kroma	32				
Kúbica	84				
Lagos	78				
Living	26				
Loft	132				
Luxury	71				
Matrix	90				
Minimal	44				
Módena	153				
Mojave	34				
Montblanc	141				
Myka	74				
Nácar	72				
Perla	88				
Petra	96				
Planet	76				
Polar	45				
Quartz	52				
Quartz Artic 3D	145				
Quartz Kenya 3D	147				
Reflections	71				
Royal	50				
Safari	64				
Simat	149				
Strato	122				
Stripes	58				
Teide	142				
Tour	24				
Tuning	157				
Vintage	16				

Carnaval

30 x 30 cm / 12"x 12"

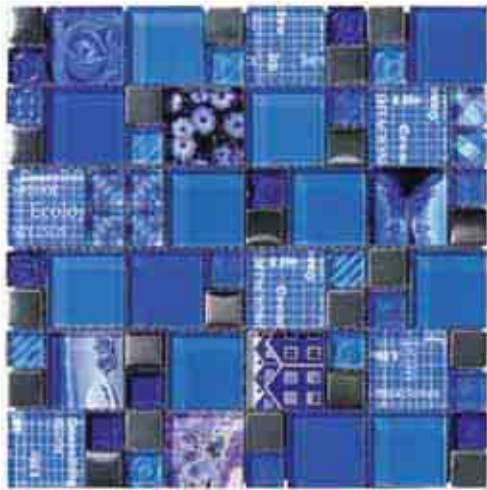

Carnaval Blue

30 x 30 cm
12"x 12"

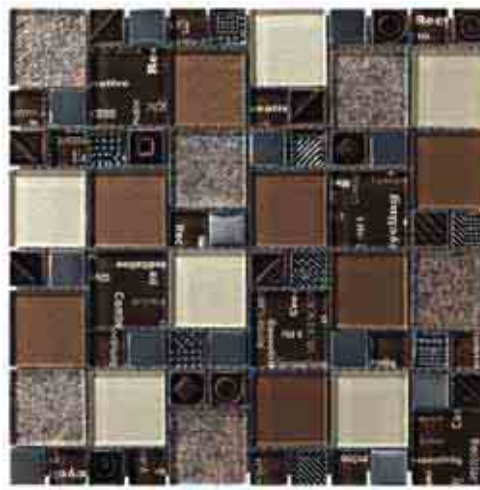

Carnaval Brown

30 x 30 cm
12"x 12"



Carnaval Silver

30 x 30 cm
12"x 12"



REVESTIMIENTO
WALL TILES



MATE-BRILLO
MATT & SHINY



DESTONIFICADO
SHADE



MOSAICO BOMALLADO
MESH MOSAIC



VIDRIO
GLASS



IMPRESIÓN DIGITAL
DIGITAL PRINTING

Carnaval

30 x 30 cm / 12"x 12"

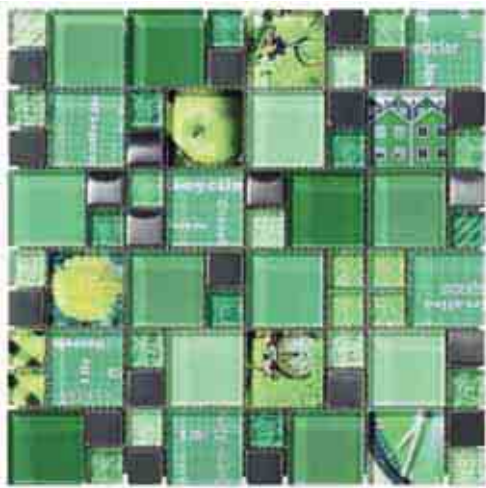

Carnaval Green

30 x 30 cm
12"x 12"



Carnaval Orange

30 x 30 cm
12"x 12"

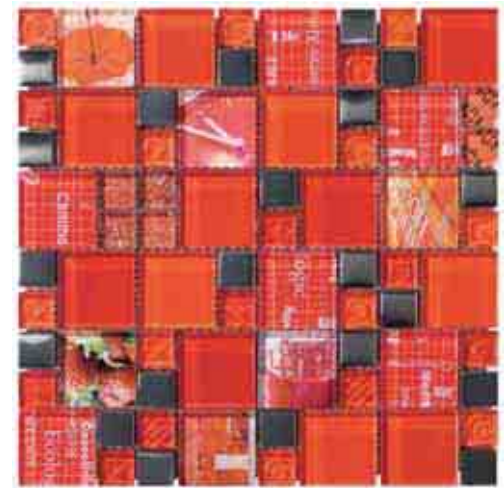

Carnaval Red

30 x 30 cm
12"x 12"

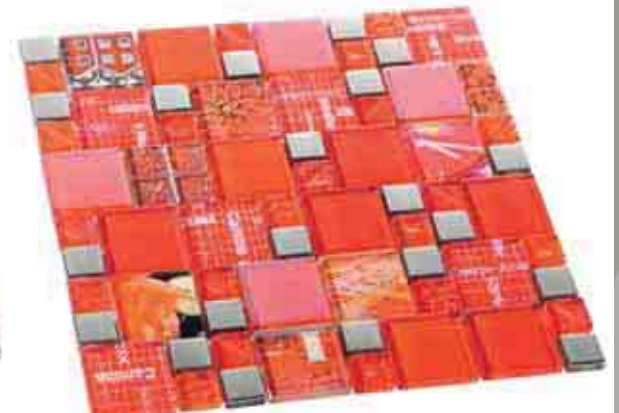
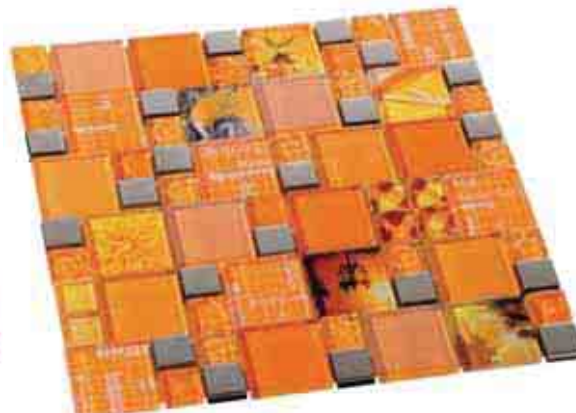
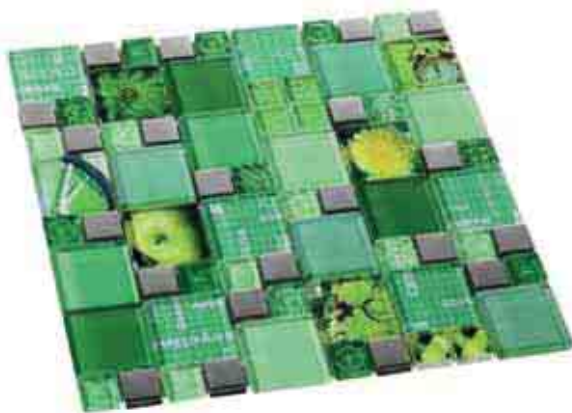

Carnaval	Pcs/Caja	m ² /Caja	Peso/Caja (Kg)	Caja/Palet	m ² /Palet	Peso/Palet (Kg)	Pcs/Caja	sq.ft./Caja	Peso/Caja	Caja/Palet	sq.ft./Palet	Peso/Palet
	Pcs/Box	m ² /Box	Weight/Box	Box/Pallet	m ² /Pallet	Weight/Pallet	Pcs/Box	sq.ft./Box	Weight/Box(lb)	Box/Pallet	sq.ft./Pallet	Weight/Pallet(lb)
	12	1,080	19,78	63	68,04	1246	12	11,63	43,61	63	732	2747



CARNAVAL BLUE

Carnaval

30 x 30 cm / 12"x 12"

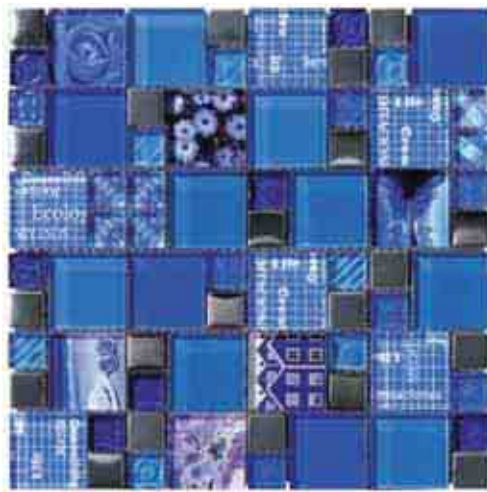

Carnaval Blue

30 x 30 cm
12"x 12"

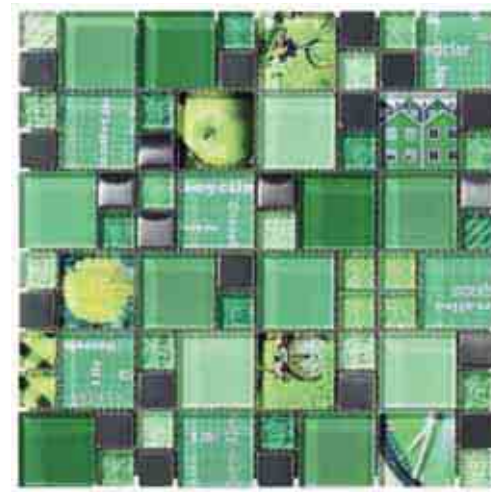

Carnaval Green

30 x 30 cm
12"x 12"

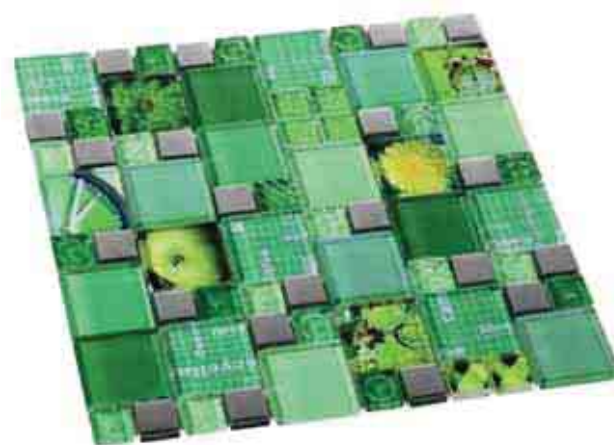
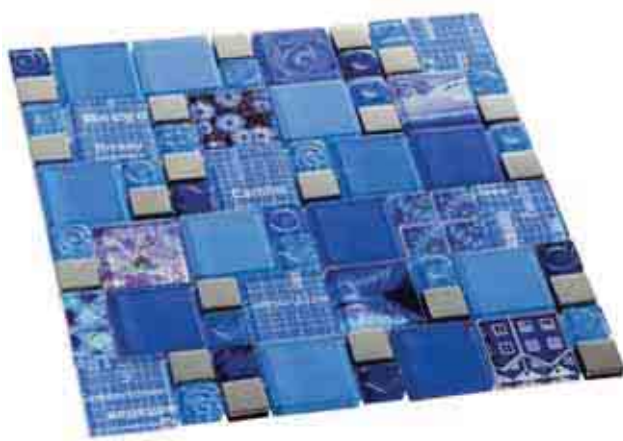

REVESTIMIENTO
WALL TILES



MATE-BRILLO
MATT & SHINY



DESTONIFICADO
SHADE



MOSAICO ENMALLADO
MESH MOSAIC



VIDRIO
GLASS



IMPRESIÓN DIGITAL
DIGITAL PRINTING

Carnaval	Pcs/Caja Pcs/Box	m ² /Caja m ² /Box	Peso/Caja (Kg) Weight/Box	Caja/Palet Box/Pallet	m ² /Palet m ² /Pallet	Peso/Palet (Kg) Weight/Pallet
	Pcs/Caja Pcs/Box	sq.ft./Caja sq.ft./Box	Peso/Caja Weight/Box(lb)	Caja/Palet Box/Pallet	sq.ft./Palet sq.ft./Pallet	Peso/Palet Weight/Pallet(lb)
	12	1,080	19,78	63	68,04	1246
	12	11,63	43,61	63	732	2747



COOK
LE
SI
BR
DES
CUI
LA
NO
EAT

SAN
TI
ES
PI
LUI
CRU
ZE
EN
GO

CARNAVAL BROWN

Carnaval

30 x 30 cm / 12"x 12"



Carnaval Brown

30 x 30 cm
12"x 12"

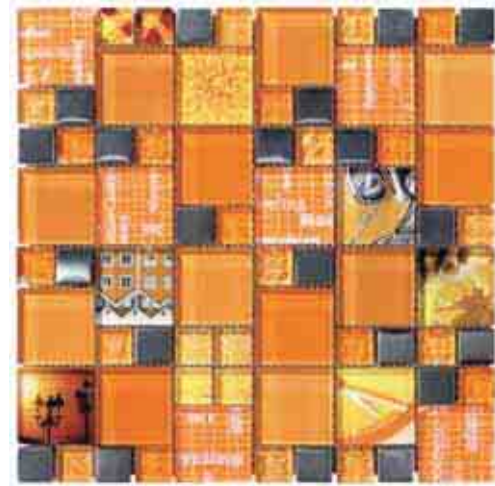

Carnaval Orange

30 x 30 cm
12"x 12"

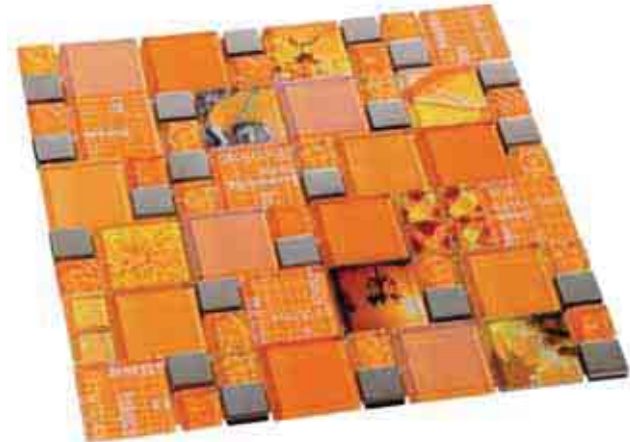

Carnaval	Pcs/Caja Pcs/Box	m ² /Caja m ² /Box	Peso/Caja (Kg) Weight/Box	Caja/Palet Box/Pallet	m ² /Palet m ² /Pallet	Peso/Palet (Kg) Weight/Pallet
	Pcs/Caja Pcs/Box	sq.ft./Caja sq.ft./Box	Peso/Caja Weight/Box(lb)	Caja/Palet Box/Pallet	sq.ft./Palet sq.ft./Pallet	Peso/Palet Weight/Pallet(lb)
	12	1,080	19,78	63	68,04	1246
	12	11,63	43,61	63	732	2747



CARNAVAL SILVER

Carnaval

30 x 30 cm / 12"x 12"

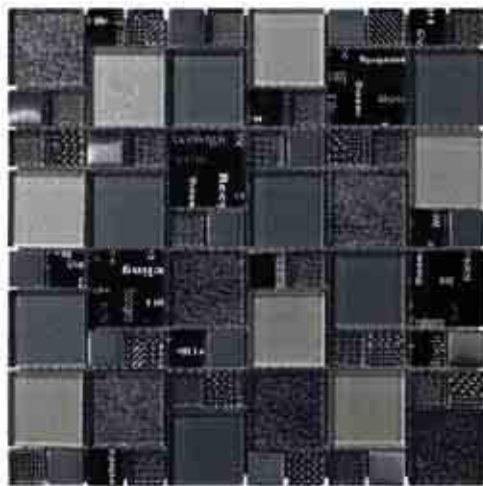

Carnaval Silver

30 x 30 cm
12"x 12"



Carnaval Red

30 x 30 cm
12"x 12"

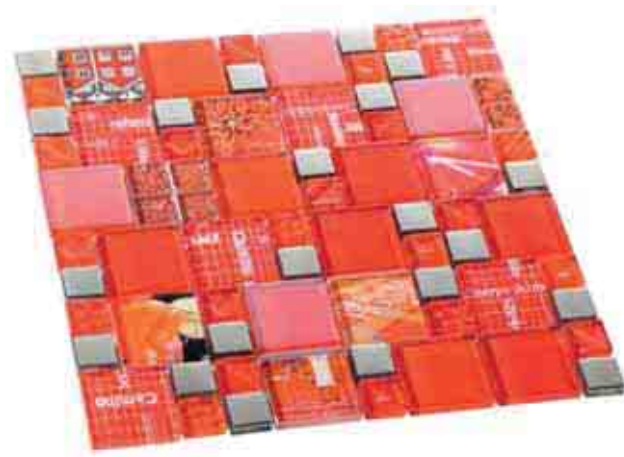

REVESTIMIENTO
WALL TILES



MATE-BRILLO
MATT & SHINY



DESTONIFICADO
SHADE



MOSAICO ENMALLADO
MESH MOSAIC



VIDRIO
GLASS



IMPRESIÓN DIGITAL
DIGITAL PRINTING

Carnaval	Pcs/Caja Pcs/Box	m ² /Caja m ² /Box	Peso/Caja (Kg) Weight/Box	Caja/Palet Box/Pallet	m ² /Palet m ² /Pallet	Peso/Palet (Kg) Weight/Pallet
	12	1,080	19,78	63	68,04	1246
Carnaval	Pcs/Caja Pcs/Box	sq.ft./Caja sq.ft./Box	Peso/Caja Weight/Box(lb)	Caja/Palet Box/Pallet	sq.ft./Palet sq.ft./Pallet	Peso/Palet Weight/Pallet(lb)
	12	11,63	43,61	63	732	2747

Vintage

30 x 30 cm / 12"x 12"



Vintage Beige

30 x 30 cm
12"x 12"

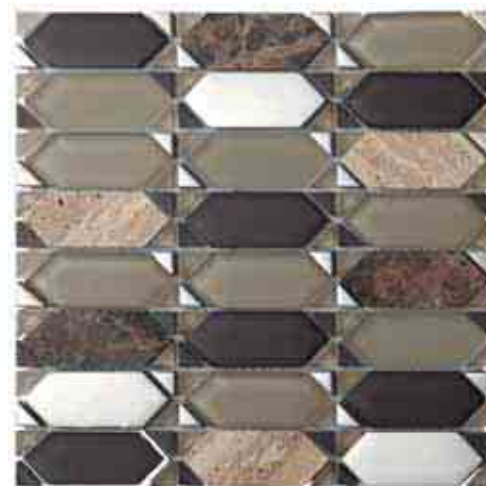

Vintage Brown

30 x 30 cm
12"x 12"

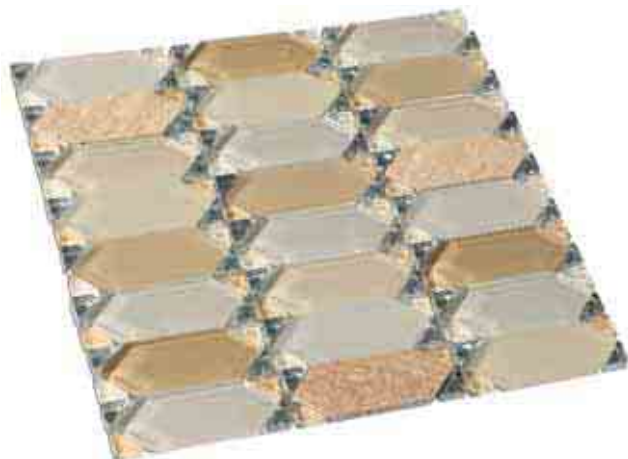

REVESTIMIENTO
WALL TILES



MATE-BRILLO
MATT & SHINY



DESTONIFICADO
SHADE



MOSACO ENMALLADO
MESH MOSAIC



MARMOL
MARBLE



VIDRIO
GLASS

Vintage

30 x 30 cm / 12"x 12"



Vintage Grey

30 x 30 cm
12"x 12"



Vintage White

30 x 30 cm
12"x 12"

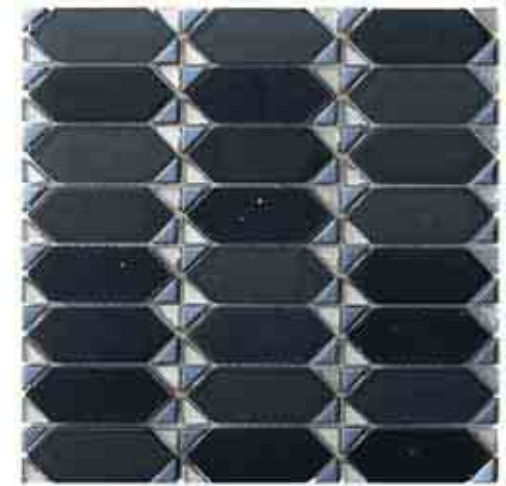

Vintage Black

30 x 30 cm
12"x 12"

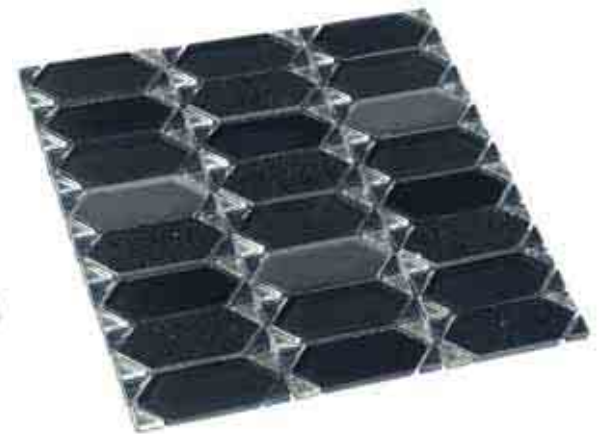

Vintage	Pcs/Caja	m ² /Caja	Peso/Caja (Kg)	Caja/Palet	m ² /Palet	Peso/Palet (Kg)	Pcs/Caja	sq.ft./Caja	Peso/Caja	Caja/Palet	sq.ft./Palet	Peso/Palet
	Pcs/Box	m ² /Box	Weight/Box	Box/Pallet	m ² /Pallet	Weight/Pallet	Pcs/Box	sq.ft./Box	Weight/Box(lb)	Box/Pallet	sq.ft./Pallet	Weight/Pallet(lb)
	12	1,080	19,06	63	68,04	1201	12	11,63	42,02	63	732	2647



VINTAGE BEIGE
VINTAGE BROWN

Vintage

30 x 30 cm / 12"x 12"



Vintage Beige

30 x 30 cm
12"x 12"



Vintage Brown

30 x 30 cm
12"x 12"

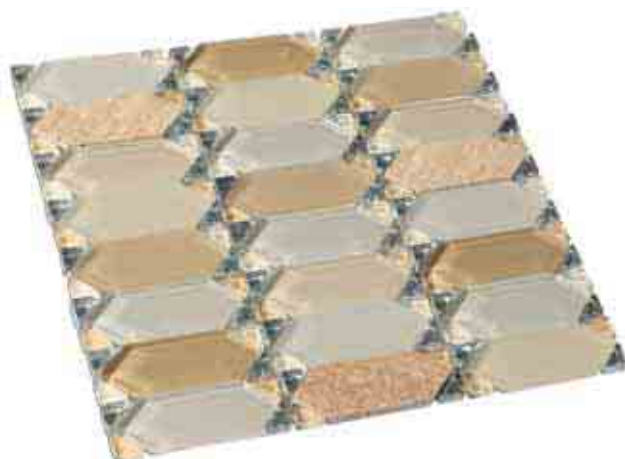

REVESTIMIENTO
WALL TILES

MATE-BRILLO
MATT & SHINY

DESTONIFICADO
SHADE

MOSAICO EMALLADO
MESH MOSAIC

MARMOL
MARBLE

VIDRIO
GLASS

Vintage	Pcs/Caja Pcs/Box	m ² /Caja m ² /Box	Peso/Caja (Kg) Weight/Box	Caja/Palet Box/Pallet	m ² /Palet m ² /Pallet	Peso/Palet (Kg) Weight/Pallet
	Pcs/Caja Pcs/Box	sq.ft./Caja sq.ft./Box	Peso/Caja Weight/Box(lb)	Caja/Palet Box/Pallet	sq.ft./Palet sq.ft./Pallet	Peso/Palet Weight/Pallet(lb)
	12	1,080	19,06	63	68,04	1201
	12	11,63	42,02	63	732	2647



VINTAGE GREY
VINTAGE WHITE

Vintage

30 x 30 cm / 12"x 12"



Vintage Grey

30 x 30 cm
12"x 12"



Vintage White

30 x 30 cm
12"x 12"



Vintage Black

30 x 30 cm
12"x 12"

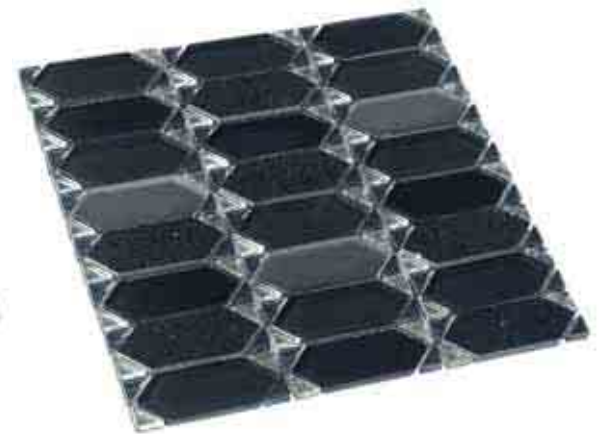

REVESTIMIENTO
WALL TILES



MATE-BRILLO
MATT & SHINY



DESTONIFICADO
SHADE



MOSAICO EMALLADO
MESH MOSAIC



MARMOL
MARBLE



VIDRIO
GLASS

Vintage	Pcs/Caja Pcs/Box	m ² /Caja m ² /Box	Peso/Caja (Kg) Weight/Box	Caja/Palet Box/Pallet	m ² /Palet m ² /Pallet	Peso/Palet (Kg) Weight/Pallet
	Pcs/Caja Pcs/Box	sq.ft./Caja sq.ft./Box	Peso/Caja Weight/Box(lb)	Caja/Palet Box/Pallet	sq.ft./Palet sq.ft./Pallet	Peso/Palet Weight/Pallet(lb)
	12	1,080	19,06	63	68,04	1201
	12	11,63	42,02	63	732	2647



ELEMENTS BEIGE

Elements

30 x 30 cm / 12"x 12"



Elements Beige

30 x 30 cm
12"x 12"



Elements Grey

30 x 30 cm
12"x 12"

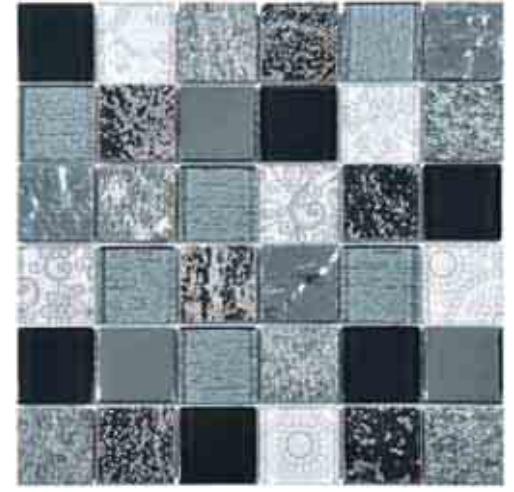

Elements Black

30 x 30 cm
12"x 12"



REVESTIMIENTO
WALL TILES



MATE-BRILLO
MATT & SHINY



DESTONIFICADO
SHADE



MOSAICO ENMALLADO
MESH MOSAIC



MARMOL
MARBLE



PIEDRA
NATURAL STONE



VIDRIO
GLASS



IMPRESIÓN DIGITAL
DIGITAL PRINTING

Elements	Pcs/Caja Pcs/Box	m ² /Caja m ² /Box	Peso/Caja (Kg) Weight/Box	Caja/Palet Box/Pallet	m ² /Palet m ² /Pallet	Peso/Palet (Kg) Weight/Pallet
	Pcs/Caja Pcs/Box	sq.ft./Caja sq.ft./Box	Peso/Caja Weight/Box(lb)	Caja/Palet Box/Pallet	sq.ft./Palet sq.ft./Pallet	Peso/Palet Weight/Pallet(lb)
	12	1,080	20,79	63	68,04	1310
	12	11,63	45,83	63	732	2888



TOUR BLACK
TOUR WHITE

Tour

30 x 30 cm / 12"x 12"

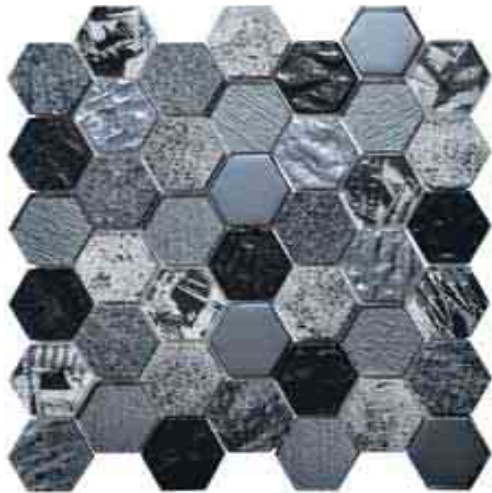

Tour Black

30 x 30 cm
12"x 12"



Tour Brown

30 x 30 cm
12"x 12"



Tour Grey

30 x 30 cm
12"x 12"



Tour White

30 x 30 cm
12"x 12"



DESTONIFICADO
SHADE



RELIEVE
RELIEF



MOSAICO ENMALLADO
MESH MOSAIC



ALUMINIO
ALUMINUM



MARMOL
MARBLE



PIEDRA
NATURAL STONE



VIDRIO
GLASS



REVESTIMIENTO
WALL TILES



MATE-BRILLO
MATT & SHINY



IMPRESIÓN DIGITAL
DIGITAL PRINTING

Tour	Pcs/Caja Pcs/Box	m ² /Caja m ² /Box	Peso/Caja (Kg) Weight/Box	Caja/Palet Box/Pallet	m ² /Palet m ² /Pallet	Peso/Palet (Kg) Weight/Pallet
	Pcs/Caja Pcs/Box	sq.ft./Caja sq.ft./Box	Peso/Caja Weight/Box(lb)	Caja/Palet Box/Pallet	sq.ft./Palet sq.ft./Pallet	Peso/Palet Weight/Pallet(lb)
	12	1,080	21,48	63	68,04	1353
	12	11,63	47,36	63	732	2983

Living

30 x 30 cm / 12"x 12"

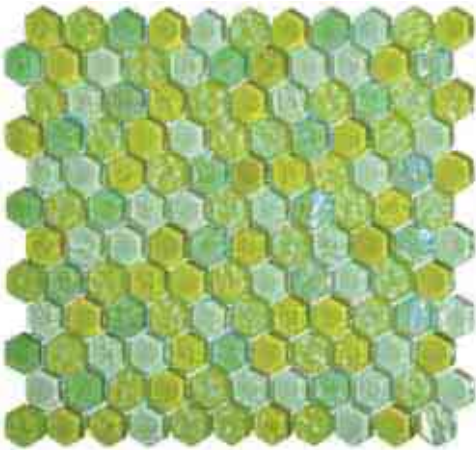

Living Green

30 x 30 cm
12"x 12"



Living White

30 x 30 cm
12"x 12"

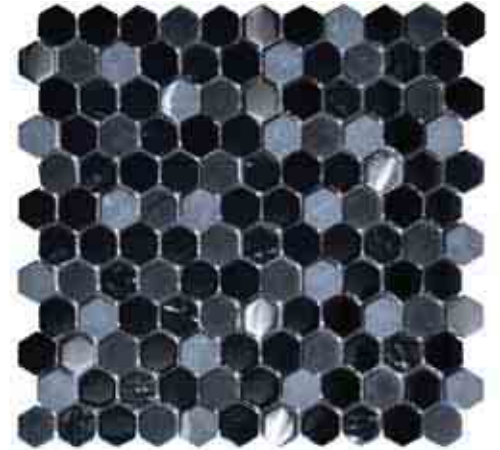

Living Black

30 x 30 cm
12"x 12"

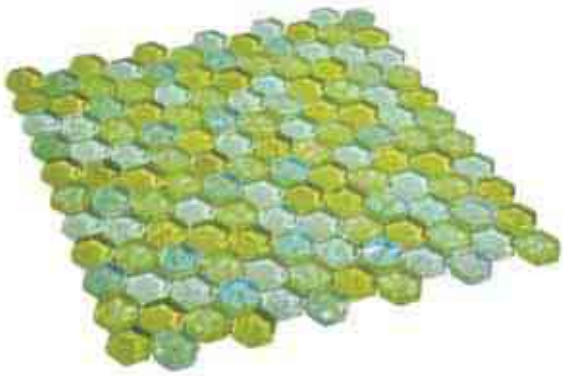

REVESTIMIENTO
WALL TILES



MATE-BRILLO
MATT & SHINY



DESTONIFICADO
SHADE



RELIEVE
RELIEF



MOSAICO ENMALLADO
MESH MOSAIC



MARMOL
MARBLE



VIDRIO
GLASS

Living

30 x 30 cm / 12"x 12"

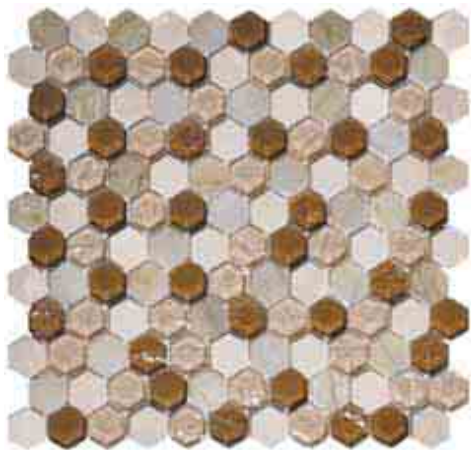

Living Beige

30 x 30 cm
12"x 12"



Living Brown

30 x 30 cm
12"x 12"

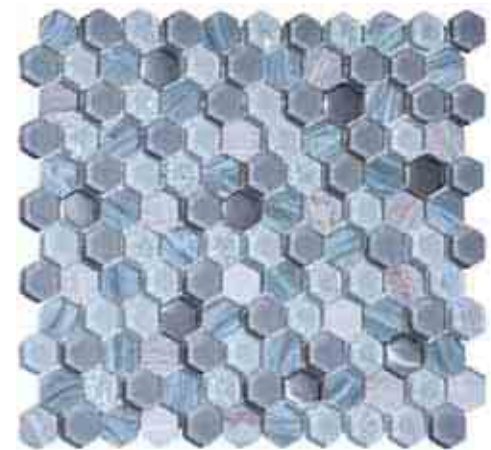

Living Grey

30 x 30 cm
12"x 12"



Living	Pcs/Caja	m ² /Caja	Peso/Caja (Kg)	Caja/Palet	m ² /Palet	Peso/Palet (Kg)	Pcs/Caja	sq.ft./Caja	Peso/Caja	Caja/Palet	sq.ft./Palet	Peso/Palet
	Pcs/Box	m ² /Box	Weight/Box	Box/Pallet	m ² /Pallet	Weight/Pallet	Pcs/Box	sq.ft./Box	Weight/Box(lb)	Box/Pallet	sq.ft./Pallet	Weight/Pallet(lb)
	12	0,998	17,20	63	62,874	1084	12	10,74	37,92	63	677	2389



LIVING GREEN
LIVING WHITE
LIVING BLACK

Living

30 x 30 cm / 12"x 12"

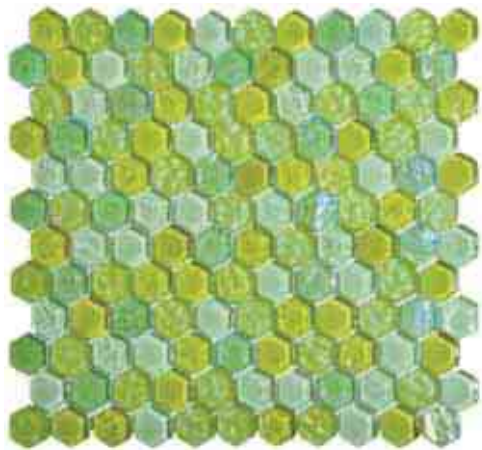

Living Green

30 x 30 cm
12"x 12"

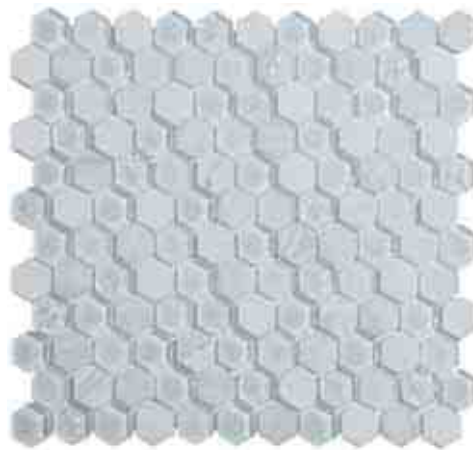

Living White

30 x 30 cm
12"x 12"

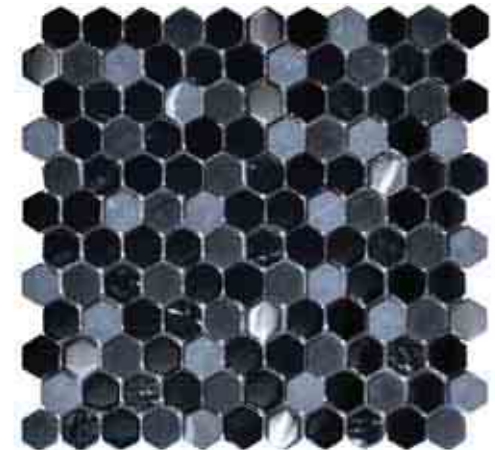

Living Black

30 x 30 cm
12"x 12"

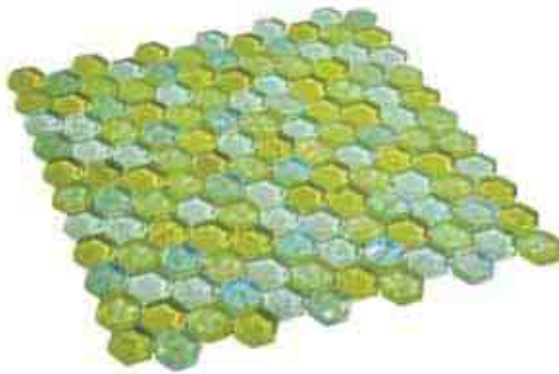

REVESTIMIENTO
WALL TILES



MATE-BRILLO
MATT & SHINY



DESTONIFICADO
SHADE



RELIEVE
RELIEF



MOSAIKO ENMALLADO
MESH MOSAIC



MARMOL
MARBLE



VIDRIO
GLASS

Living	Pcs/Caja Pcs/Box	m ² /Caja m ² /Box	Peso/Caja (Kg) Weight/Box	Caja/Palet Box/Pallet	m ² /Palet m ² /Pallet	Peso/Palet (Kg) Weight/Pallet
	Pcs/Caja Pcs/Box	sq.ft./Caja sq.ft./Box	Peso/Caja Weight/Box(lb)	Caja/Palet Box/Pallet	sq.ft./Palet sq.ft./Pallet	Peso/Palet Weight/Pallet(lb)
	12	0,998	17,20	63	62,874	1084
	12	10,74	37,92	63	677	2389



LIVING GREY
LIVING WHITE

Living

30 x 30 cm / 12"x 12"

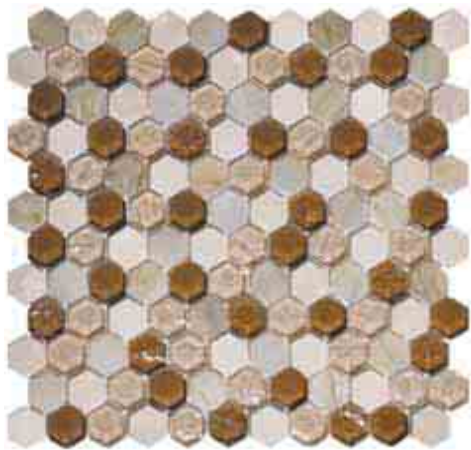

Living Beige

30 x 30 cm
12"x 12"



Living Brown

30 x 30 cm
12"x 12"



Living Grey

30 x 30 cm
12"x 12"



REVESTIMIENTO
WALL TILES



MATE-BRILLO
MATT & SHINY



DESTONIFICADO
SHADE



RELIEVE
RELIEF



MOSACO EMALLADO
MESH MOSAIC



MARMOL
MARBLE



VIDRIO
GLASS

Living	Pcs/Caja Pcs/Box	m ² /Caja m ² /Box	Peso/Caja (Kg) Weight/Box	Caja/Palet Box/Pallet	m ² /Palet m ² /Pallet	Peso/Palet (Kg) Weight/Pallet
	Pcs/Caja Pcs/Box	sq.ft./Caja sq.ft./Box	Peso/Caja Weight/Box(lb)	Caja/Palet Box/Pallet	sq.ft./Palet sq.ft./Pallet	Peso/Palet Weight/Pallet(lb)
	12	0,998	17,20	63	62,874	1084
	12	10,74	37,92	63	677	2389



KROMA SILVER
KROMA SAPPHIRE

Kroma

30 x 30 cm / 12"x 12"

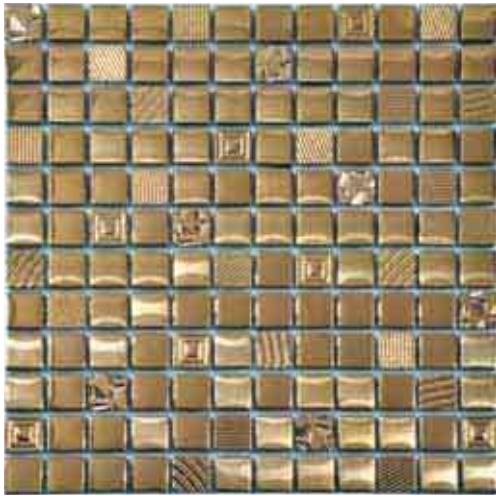

Kroma Gold

30 x 30 cm
12"x 12"



Kroma Sapphire

30 x 30 cm
12"x 12"



Kroma Silver

30 x 30 cm
12"x 12"

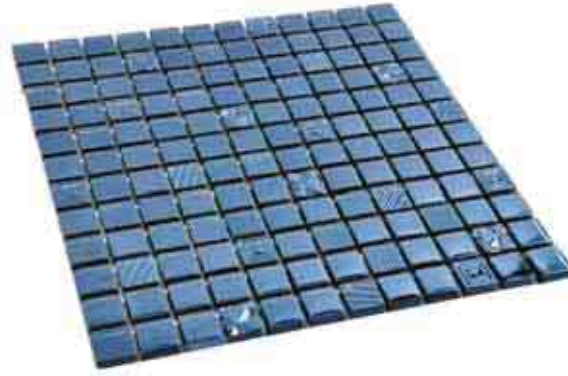
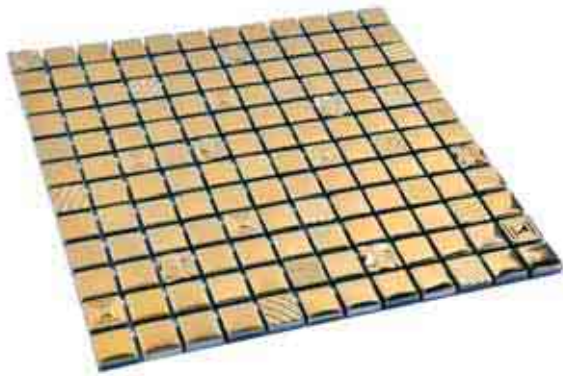

REVESTIMIENTO
WALL TILES

MATE-BRILLO
MATT & SHINY

RELIEVE
RELIEF

MOSAICO EMALLADO
MESH MOSAIC

VIDRIO
GLASS

Kroma	Pcs/Caja Pcs/Box	m ² /Caja m ² /Box	Peso/Caja (Kg) Weight/Box	Caja/Palet Box/Pallet	m ² /Palet m ² /Pallet	Peso/Palet (Kg) Weight/Pallet
	Pcs/Caja Pcs/Box	sq.ft./Caja sq.ft./Box	Peso/Caja Weight/Box(lb)	Caja/Palet Box/Pallet	sq.ft./Palet sq.ft./Pallet	Peso/Palet Weight/Pallet(lb)
	12	1,080	18,67	63	68,04	1176
	12	11,63	41,16	63	732	2593



MOJAVE GRAPHITE
MOJAVE SALT

Mojave

30 x 30 cm / 12"x 12"

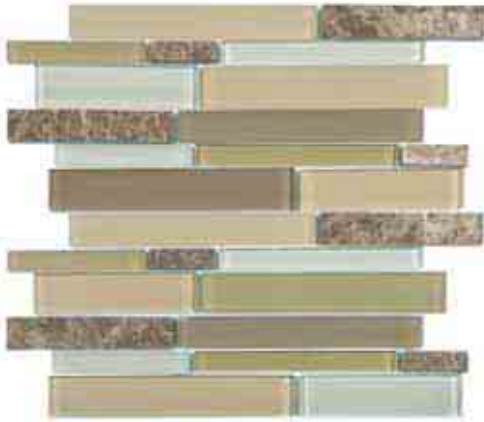

Mojave Almond

30 x 30 cm
12"x 12"



Mojave Graphite

30 x 30 cm
12"x 12"



Mojave Salt

30 x 30 cm
12"x 12"



DESTONIFICADO
SHADE



RELIEVE
RELIEF



MOSAICO ENMALLADO
MESH MOSAIC



ALUMINIO
ALUMINUM



MARMOL
MARBLE



PIEDRA
NATURAL STONE



VIDRIO
GLASS



REVESTIMIENTO
WALL TILES



MATE-BRILLO
MATT & SHINY

Mojave	Pcs/Caja Pcs/Box	m ² /Caja m ² /Box	Peso/Caja (Kg) Weight/Box	Caja/Palet Box/Pallet	m ² /Palet m ² /Pallet	Peso/Palet (Kg) Weight/Pallet
	Pcs/Caja Pcs/Box	sq.ft./Caja sq.ft./Box	Peso/Caja Weight/Box(lb)	Caja/Palet Box/Pallet	sq.ft./Palet sq.ft./Pallet	Peso/Palet Weight/Pallet(lb)
	12	1,080	20,63	63	68,04	1300
	12	11,63	45,48	63	732	2865



MARRAKECH FASHION

Marrakech

30 x 30 cm / 12"x 12"



Classic

30 x 30 cm
12"x 12"



Faenza

30 x 30 cm
12"x 12"



Fashion

30 x 30 cm
12"x 12"



Minimal

30 x 30 cm
12"x 12"

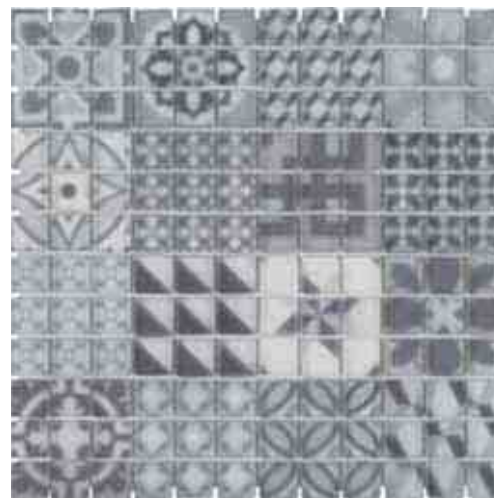

Polar

30 x 30 cm
12"x 12"



REVESTIMIENTO
WALL TILES



BRILLO
SHINY

POLAR



MATE
MATT



DESTONIFICADO
SHADE



MOSACO ENMALLADO
MESH MOSAIC



VIDRIO
GLASS



IMPRESIÓN DIGITAL
DIGITAL PRINTING

Marrakech	Pcs/Caja Pcs/Box	m ² /Caja m ² /Box	Peso/Caja (Kg) Weight/Box	Caja/Palet Box/Pallet	m ² /Palet m ² /Pallet	Peso/Palet (Kg) Weight/Pallet
	Pcs/Caja Pcs/Box	sq.ft./Caja sq.ft./Box	Peso/Caja Weight/Box(lb)	Caja/Palet Box/Pallet	sq.ft./Palet sq.ft./Pallet	Peso/Palet Weight/Pallet(lb)
	12	1,080	18,70	63	68,04	1178
	12	11,63	41,23	63	732	2597



MARRAKECH CLASSIC

Marrakech

30 x 30 cm / 12"x 12"



Classic

30 x 30 cm
12"x 12"

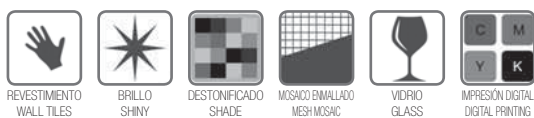

Marrakech	Pcs/Caja Pcs/Box	m ² /Caja m ² /Box	Peso/Caja (Kg) Weight/Box	Caja/Palet Box/Pallet	m ² /Palet m ² /Pallet	Peso/Palet (Kg) Weight/Pallet
	Pcs/Caja Pcs/Box	sq.ft./Caja sq.ft./Box	Peso/Caja Weight/Box(lb)	Caja/Palet Box/Pallet	sq.ft./Palet sq.ft./Pallet	Peso/Palet Weight/Pallet(lb)
	12	1,080	18,70	63	68,04	1178
	12	11,63	41,23	63	732	2597



MARRAKECH FAENZA

Marrakech

30 x 30 cm / 12"x 12"



Faenza

30 x 30 cm
12"x 12"



REVESTIMIENTO
WALL TILES

BRILLO
SHINY

DESTONIFICADO
SHADE

MOSAICO EMALLADO
MESH MOSAIC

VIDRIO
GLASS

IMPRESIÓN DIGITAL
DIGITAL PRINTING

Marrakech	Pcs/Caja Pcs/Box	m ² /Caja m ² /Box	Peso/Caja (Kg) Weight/Box	Caja/Palet Box/Pallet	m ² /Palet m ² /Pallet	Peso/Palet (Kg) Weight/Pallet
	12	1,080	18,70	63	68,04	1178
Marrakech	Pcs/Caja Pcs/Box	sq.ft./Caja sq.ft./Box	Peso/Caja Weight/Box(lb)	Caja/Palet Box/Pallet	sq.ft./Palet sq.ft./Pallet	Peso/Palet Weight/Pallet(lb)
	12	11,63	41,23	63	732	2597



MARRAKECH FASHION

Marrakech

30 x 30 cm / 12"x 12"



Fashion

30 x 30 cm
12"x 12"

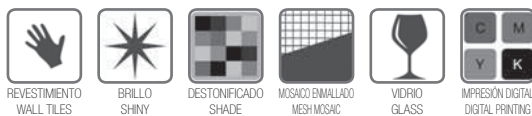

REVESTIMIENTO
WALL TILES

BRILLO
SHINY

DESTONIFICADO
SHADE

MOSAICO ENMALLADO
MESH MOSAIC

VIDRIO
GLASS

IMPRESIÓN DIGITAL
DIGITAL PRINTING

Marrakech	Pcs/Caja Pcs/Box	m ² /Caja m ² /Box	Peso/Caja (Kg) Weight/Box	Caja/Palet Box/Pallet	m ² /Palet m ² /Pallet	Peso/Palet (Kg) Weight/Pallet
	Pcs/Caja Pcs/Box	sq.ft./Caja sq.ft./Box	Peso/Caja Weight/Box(lb)	Caja/Palet Box/Pallet	sq.ft./Palet sq.ft./Pallet	Peso/Palet Weight/Pallet(lb)
	12	1,080	18,70	63	68,04	1178
	12	11,63	41,23	63	732	2597

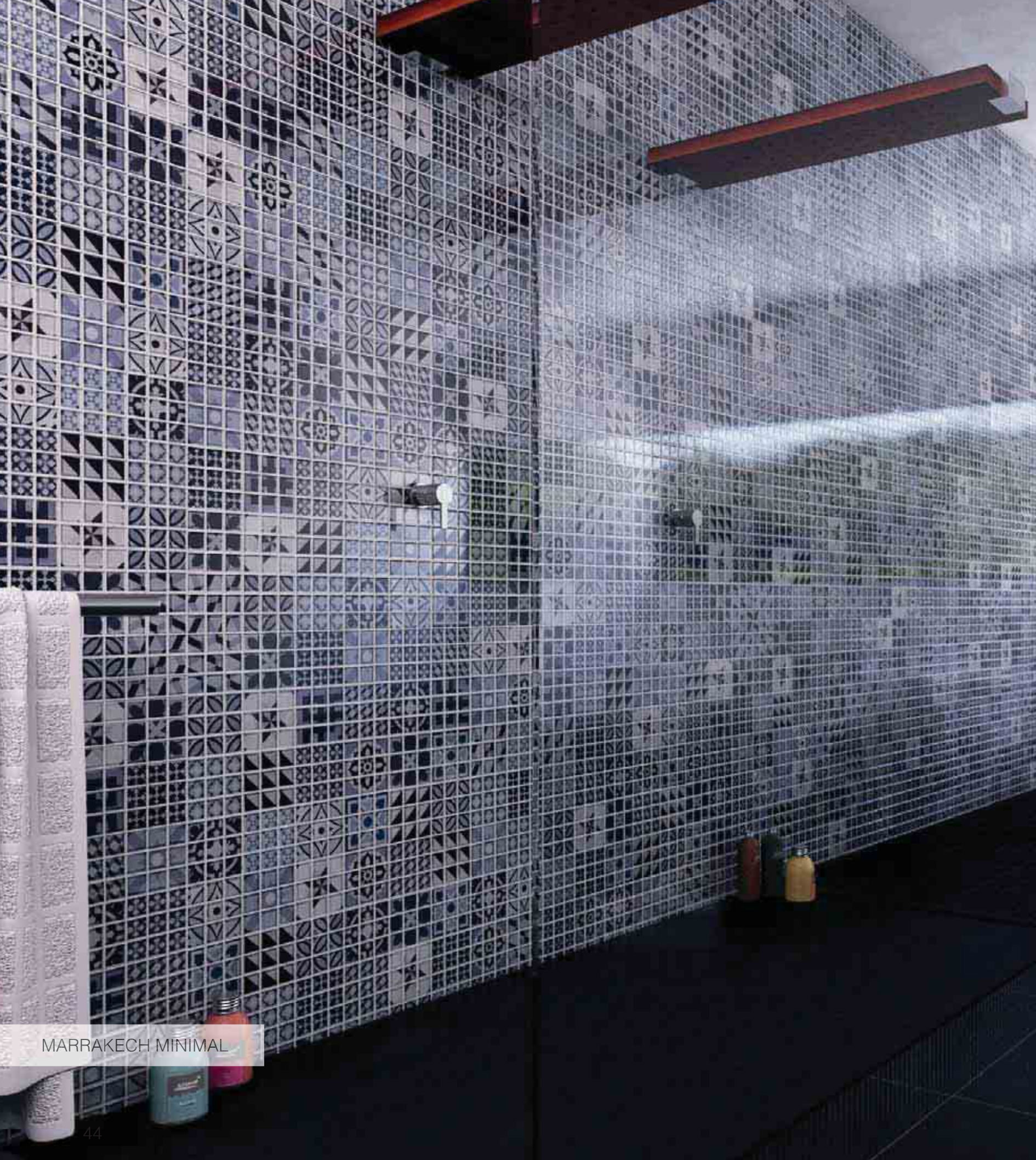

MARRAKECH MINIMAL

Marrakech

30 x 30 cm / 12"x 12"



Minimal

30 x 30 cm
12"x 12"

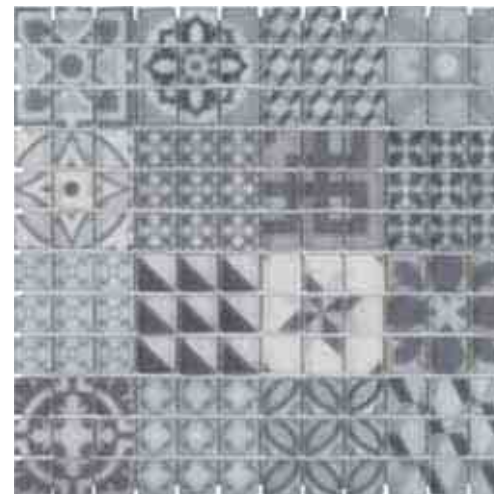

Polar

30 x 30 cm
12"x 12"



Marrakech	Pcs/Caja Pcs/Box	m ² /Caja m ² /Box	Peso/Caja (Kg) Weight/Box	Caja/Palet Box/Pallet	m ² /Palet m ² /Pallet	Peso/Palet (Kg) Weight/Pallet
	Pcs/Caja Pcs/Box	sq.ft./Caja sq.ft./Box	Peso/Caja Weight/Box(lb)	Caja/Palet Box/Pallet	sq.ft./Palet sq.ft./Pallet	Peso/Palet Weight/Pallet(lb)
	12	1,080	18,70	63	68,04	1178
	12	11,63	41,23	63	732	2597



FRAME SILVER

Exclusive

30 x 30 cm / 12"x 12"

MOSAIC

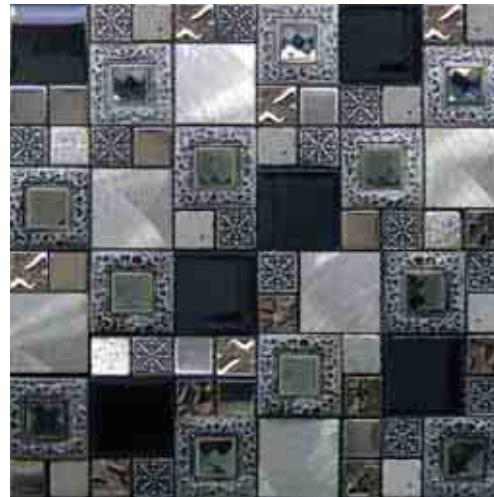

Frame Silver

30 x 30 cm
12"x 12"

ESSENTIA



REVESTIMIENTO
WALL TILES

MATE-BRILLO
MATT & SHINY

DESTONIFICADO
SHADE

RELIEVE
RELIEF

MOSAICO ENMALLADO
MESH MOSAIC

ALUMINIO
ALUMINUM

MARMOL
MARBLE

VIDRIO
GLASS

Exclusive Frame Silver	Pcs/Caja Pcs/Box	m ² /Caja m ² /Box	Peso/Caja (Kg) Weight/Box	Caja/Palet Box/Pallet	m ² /Palet m ² /Pallet	Peso/Palet (Kg) Weight/Pallet
	Pcs/Caja Pcs/Box	sq.ft./Caja sq.ft./Box	Peso/Caja Weight/Box(lb)	Caja/Palet Box/Pallet	sq.ft./Palet sq.ft./Pallet	Peso/Palet Weight/Pallet(lb)
	12	1,080	16,40	63	68,04	1033
	12	11,63	36,16	63	732	2278

PORCELAIN



KAOS SILVER

Exclusive

30 x 30 cm / 12"x 12"

MOSAIC

ESSENTIA



Kaos Silver

30 x 30 cm
12"x 12"



REVESTIMIENTO
WALL TILES



MATE-BRILLO
MATT & SHINY



DESTONIFICADO
SHADE



RELIEVE
RELIEF



MOSAICO ENMALLADO
MESH MOSAIC



ALUMINIO
ALUMINUM



VIDRIO
GLASS

Exclusive Kaos Silver	Pcs/Caja Pcs/Box	m ² /Caja m ² /Box	Peso/Caja (Kg) Weight/Box	Caja/Palet Box/Pallet	m ² /Palet m ² /Pallet	Peso/Palet (Kg) Weight/Pallet
	Pcs/Caja Pcs/Box	sq.ft./Caja sq.ft./Box	Peso/Caja Weight/Box(lb)	Caja/Palet Box/Pallet	sq.ft./Palet sq.ft./Pallet	Peso/Palet Weight/Pallet(lb)
	12	1,080	16,17	63	68,04	1019
	12	11,63	35,65	63	732	2246

PORCELAIN



ROYAL GREY
ROYAL WHITE

Royal

30 x 30 cm / 12"x 12"

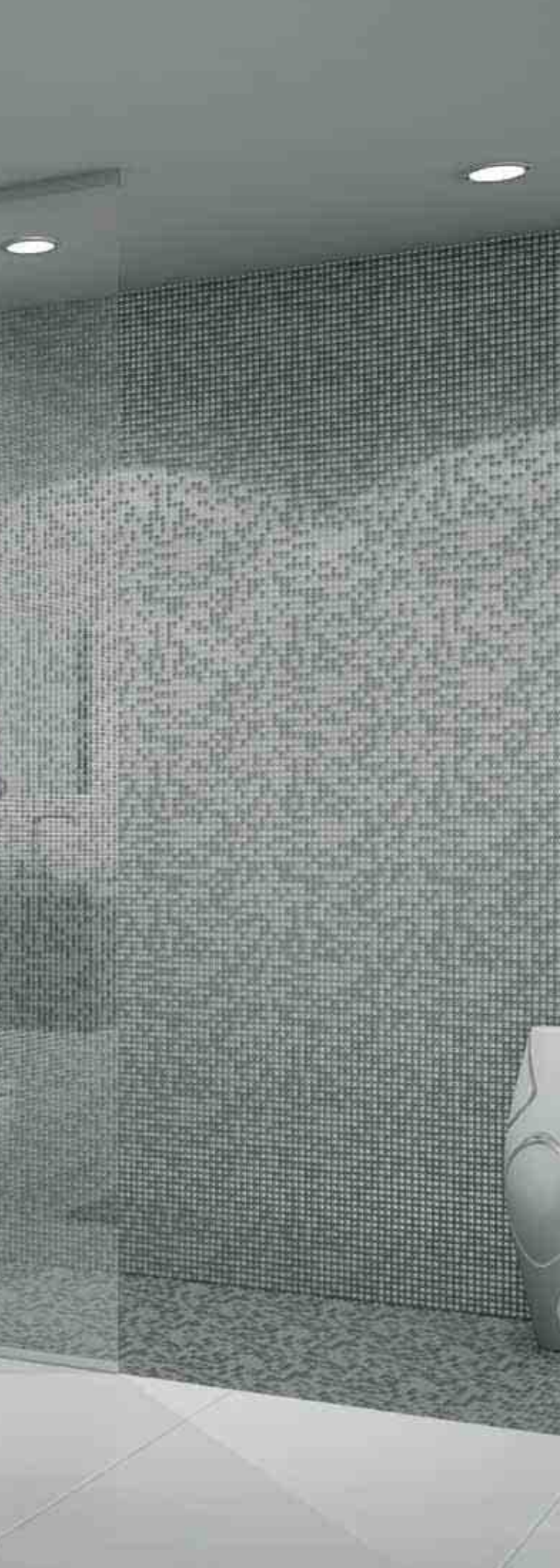

Roayl Grey

30 x 30 cm
12"x 12"



Roayl White

30 x 30 cm
12"x 12"



REVESTIMIENTO
WALL TILES



BRILLO
SHINY



RELIEVE
RELIEF



MOSADO ENMALLADO
MESH MOSAIC



VIDRIO
GLASS

Royal	Pcs/Caja Pcs/Box	m ² /Caja m ² /Box	Peso/Caja (Kg) Weight/Box	Caja/Palet Box/Pallet	m ² /Palet m ² /Pallet	Peso/Palet (Kg) Weight/Pallet
	Pcs/Caja Pcs/Box	sq.ft./Caja sq.ft./Box	Peso/Caja Weight/Box(lb)	Caja/Palet Box/Pallet	sq.ft./Palet sq.ft./Pallet	Peso/Palet Weight/Pallet(lb)
	12	1,080	13,50	63	68,04	851
	12	11,63	29,76	63	732	1875



QUARTZ BLACK
REFLECTIONS

Quartz

30 x 30 cm / 12"x 12"



Quartz Black 30 x 30 cm
12"x 12"



Quartz Grey 30 x 30 cm
12"x 12"



Quartz White 30 x 30 cm
12"x 12"



Quartz Red 30 x 30 cm
12"x 12"



Quartz	Pcs/Caja Pcs/Box	m ² /Caja m ² /Box	Peso/Caja (Kg) Weight/Box	Caja/Palet Box/Pallet	m ² /Palet m ² /Pallet	Peso/Palet (Kg) Weight/Pallet
	Pcs/Caja Pcs/Box	sq.ft./Caja sq.ft./Box	Peso/Caja Weight/Box(lb)	Caja/Palet Box/Pallet	sq.ft./Palet sq.ft./Pallet	Peso/Palet Weight/Pallet(lb)
	12	0,990	17,32	63	62,37	1091
	12	10,66	38,18	63	671	2406



QUARTZ BLACK
QUARTZ WHITE

Quartz

30 x 30 cm / 12"x 12"



Quartz Black

30 x 30 cm
12"x 12"

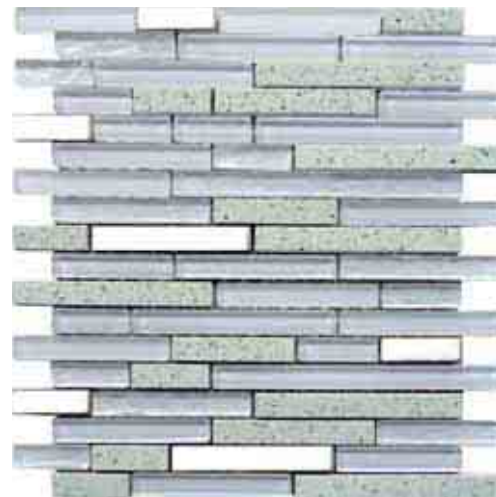

Quartz White

30 x 30 cm
12"x 12"



REVESTIMIENTO
WALL TILES



MATE-BRILLO
MATT & SHINY



DESTONIFICADO
SHADE



MOSAICO ENMALLADO
MESH MOSAIC



VIDRIO
GLASS



CUARZO ARTIFICIAL
QUARTZ STONE

Quartz	Pcs/Caja Pcs/Box	m ² /Caja m ² /Box	Peso/Caja (Kg) Weight/Box	Caja/Palet Box/Pallet	m ² /Palet m ² /Pallet	Peso/Palet (Kg) Weight/Pallet
	Pcs/Caja Pcs/Box	sq.ft./Caja sq.ft./Box	Peso/Caja Weight/Box(lb)	Caja/Palet Box/Pallet	sq.ft./Palet sq.ft./Pallet	Peso/Palet Weight/Pallet(lb)
	12	0,990	17,32	63	62,37	1091
	12	10,66	38,18	63	671	2406



QUARTZ RED

Quartz

30 x 30 cm / 12"x 12"



Quartz Grey

30 x 30 cm
12"x 12"



Quartz Red

30 x 30 cm
12"x 12"



REVESTIMIENTO
WALL TILES



MATE-BRILLO
MATT & SHINY



DESTONIFICADO
SHADE



MOSAICO ENMALLADO
MESH MOSAIC



VIDRIO
GLASS



CUARZO ARTIFICIAL
QUARTZ STONE

Quartz	Pcs/Caja Pcs/Box	m ² /Caja m ² /Box	Peso/Caja (Kg) Weight/Box	Caja/Palet Box/Pallet	m ² /Palet m ² /Pallet	Peso/Palet (Kg) Weight/Pallet
	12	0,990	17,32	63	62,37	1091
Quartz	Pcs/Caja Pcs/Box	sq.ft./Caja sq.ft./Box	Peso/Caja Weight/Box(lb)	Caja/Palet Box/Pallet	sq.ft./Palet sq.ft./Pallet	Peso/Palet Weight/Pallet(lb)
	12	10,66	38,18	63	671	2406



STRIPES SUNSET
STRIPES CHAMPAGNE

Stripes

30 x 30 cm / 12"x 12"

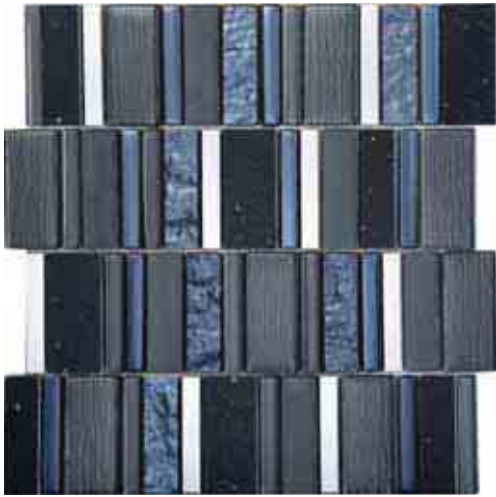

Stripes Carbon

30 x 30 cm
12"x 12"



Stripes Champagne

30 x 30 cm
12"x 12"



Stripes Cinnamon

30 x 30 cm
12"x 12"



Stripes Cold

30 x 30 cm
12"x 12"



Stripes Sunset

30 x 30 cm
12"x 12"



REVESTIMIENTO
WALL TILES

MATE-BRILLO
MATT & SHINY

DESTONIFICADO
SHADE

MOSAICO EMALLADO
MESH MOSAIC

MARMOL
MARBLE

VIDRIO
GLASS

METAL
METALLIC

Stripes	Pcs/Caja Pcs/Box	m ² /Caja m ² /Box	Peso/Caja (Kg) Weight/Box	Caja/Palet Box/Pallet	m ² /Palet m ² /Pallet	Peso/Palet (Kg) Weight/Pallet
	Pcs/Caja Pcs/Box	sq.ft./Caja sq.ft./Box	Peso/Caja Weight/Box(lb)	Caja/Palet Box/Pallet	sq.ft./Palet sq.ft./Pallet	Peso/Palet Weight/Pallet(lb)
	12	1,113	20,00	63	70,119	1260
	12	11,98	44,09	63	755	2778



IMPERIUM GOLD
IMPERIUM SILVER

Imperium

30 x 30 cm / 12"x 12"

MOSAIC



Imperium Gold

30 x 30 cm
12"x 12"

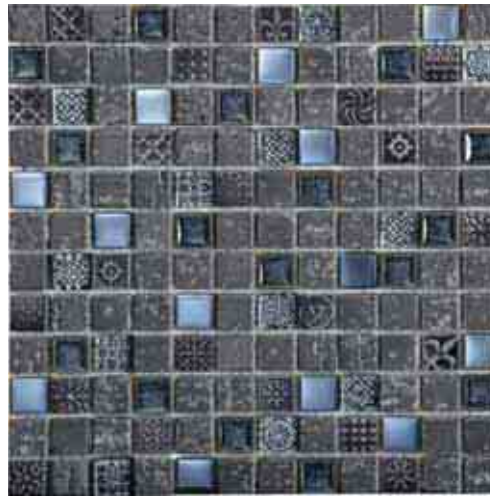

Imperium Graphite

30 x 30 cm
12"x 12"



Imperium Silver

30 x 30 cm
12"x 12"

ESSENTIA

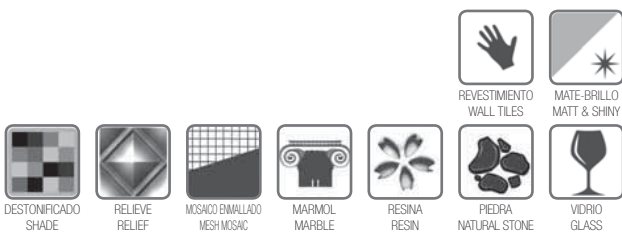

Imperium	Pcs/Caja Pcs/Box	m ² /Caja m ² /Box	Peso/Caja (Kg) Weight/Box	Caja/Palet Box/Pallet	m ² /Palet m ² /Pallet	Peso/Palet (Kg) Weight/Pallet
	Pcs/Caja Pcs/Box	sq.ft./Caja sq.ft./Box	Peso/Caja Weight/Box(lb)	Caja/Palet Box/Pallet	sq.ft./Palet sq.ft./Pallet	Peso/Palet Weight/Pallet(lb)
	12	1,080	17,52	63	68,04	1104
	12	11,63	38,62	63	732	2433

PORCELAIN



ARTIST BLACK
ARTIST WHITE

Artist

30 x 30 cm / 12"x 12"

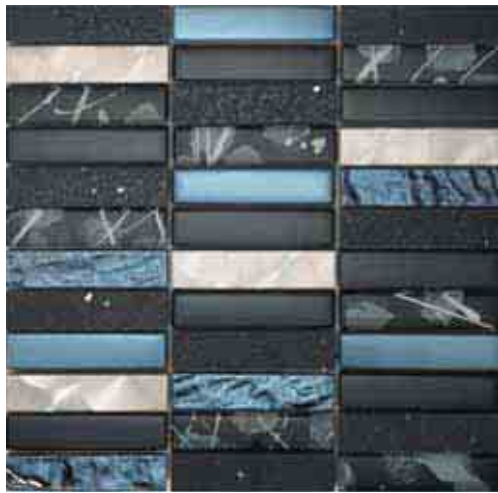

Artist Black

30 x 30 cm
12"x 12"



Artist Brown

30 x 30 cm
12"x 12"



Artist Cream

30 x 30 cm
12"x 12"



Artist Grey

30 x 30 cm
12"x 12"



Artist White

30 x 30 cm
12"x 12"



MOSAIKO ENMALLADO
MESH MOSAIC



MARMOL
MARBLE



CERAMICA
CERAMIC



VIDRIO
GLASS



CUARZO ARTIFICIAL
QUARTZ STONE



METAL
METALLIC



PINTADO A MANO
HAND PAINTED



REVESTIMIENTO
WALL TILES



MATE-BRILLO
MATT & SHINY



DESTONIFICADO
SHADE

Artist	Pcs/Caja Pcs/Box	m ² /Caja m ² /Box	Peso/Caja (Kg) Weight/Box	Caja/Palet Box/Pallet	m ² /Palet m ² /Pallet	Peso/Palet (Kg) Weight/Pallet
	Pcs/Caja Pcs/Box	sq.ft./Caja sq.ft./Box	Peso/Caja Weight/Box(lb)	Caja/Palet Box/Pallet	sq.ft./Palet sq.ft./Pallet	Peso/Palet Weight/Pallet(lb)
	12	1,080	19,70	63	68,04	1241
	12	11,63	43,43	63	732	2736



SAFARI ZEBRA
LUXURY SILVER

Safari

30 x 30 cm / 12"x 12"



Safari Elephant

30 x 30 cm
12"x 12"



Safari Leopard

30 x 30 cm
12"x 12"



Safari Zebra

30 x 30 cm
12"x 12"



Safari Tiger

30 x 30 cm
12"x 12"



DESTONIFICADO
SHADE



MOSAICO ENMALLADO
MESH MOSAIC



ALUMINIO
ALUMINUM



MÁRMOL
MARBLE



CERÁMICA
CERAMIC



VIDRIO
GLASS



CUARZO ARTIFICIAL
QUARTZ STONE



REVESTIMIENTO
WALL TILES



MATE-BRILLO
MATT & SHINY

Safari	Pcs/Caja Pcs/Box	m ² /Caja m ² /Box	Peso/Caja (Kg) Weight/Box	Caja/Palet Box/Pallet	m ² /Palet m ² /Pallet	Peso/Palet (Kg) Weight/Pallet
	Pcs/Caja Pcs/Box	sq.ft./Caja sq.ft./Box	Peso/Caja Weight/Box(lb)	Caja/Palet Box/Pallet	sq.ft./Palet sq.ft./Pallet	Peso/Palet Weight/Pallet(lb)
	12	1,080	18,38	63	68,04	1158
	12	11,63	40,52	63	732	2553



SAFARI ELEPHANT

Safari

30 x 30 cm / 12"x 12"



Safari Elephant

30 x 30 cm
12"x 12"



Safari Zebra

30 x 30 cm
12"x 12"



REVESTIMIENTO
WALL TILES



MATE-BRILLO
MATT & SHINY



DESTONIFICADO
SHADE



MOSAICO ENMALLADO
MESH MOSAIC



ALUMINIO
ALUMINIUM



MARMOL
MARBLE



CERAMICA
CERAMIC



VIDRIO
GLASS



CUARZO ARTIFICIAL
QUARTZ STONE

Safari	Pcs/Caja Pcs/Box	m ² /Caja m ² /Box	Peso/Caja (Kg) Weight/Box	Caja/Palet Box/Pallet	m ² /Palet m ² /Pallet	Peso/Palet (Kg) Weight/Pallet
	12	1,080	18,38	63	68,04	1158
Safari	Pcs/Caja Pcs/Box	sq.ft./Caja sq.ft./Box	Peso/Caja Weight/Box(lb)	Caja/Palet Box/Pallet	sq.ft./Palet sq.ft./Pallet	Peso/Palet Weight/Pallet(lb)
	12	11,63	40,52	63	732	2553



SAFARI LEOPARD

Safari

30 x 30 cm / 12"x 12"



Safari Leopard

30 x 30 cm
12"x 12"



Safari Tiger

30 x 30 cm
12"x 12"



Safari	Pcs/Caja Pcs/Box	m ² /Caja m ² /Box	Peso/Caja (Kg) Weight/Box	Caja/Palet Box/Pallet	m ² /Palet m ² /Pallet	Peso/Palet (Kg) Weight/Pallet
	Pcs/Caja Pcs/Box	sq.ft./Caja sq.ft./Box	Peso/Caja Weight/Box(lb)	Caja/Palet Box/Pallet	sq.ft./Palet sq.ft./Pallet	Peso/Palet Weight/Pallet(lb)
	12	1,080	18,38	63	68,04	1158
	12	11,63	40,52	63	732	2553



LUXURY GOLD
LUXURY SILVER

Elegance

30 x 30 cm / 12"x 12"



Luxury Silver

30 x 30 cm
12"x 12"

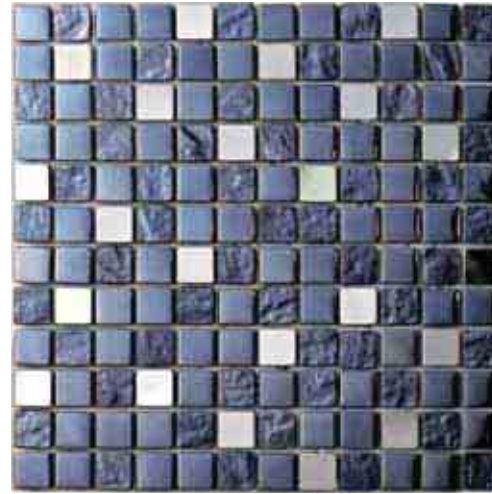

Diamond

30 x 30 cm
12"x 12"

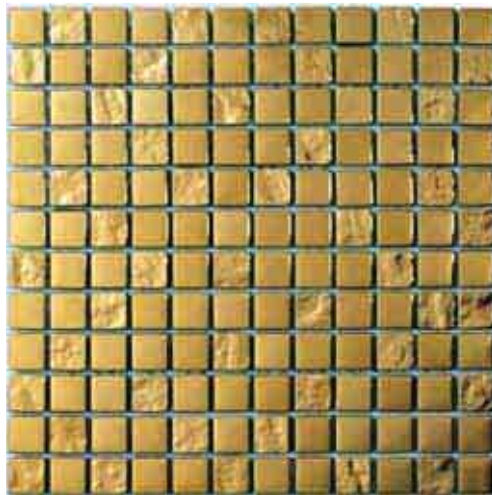

Luxury Gold

30 x 30 cm
12"x 12"

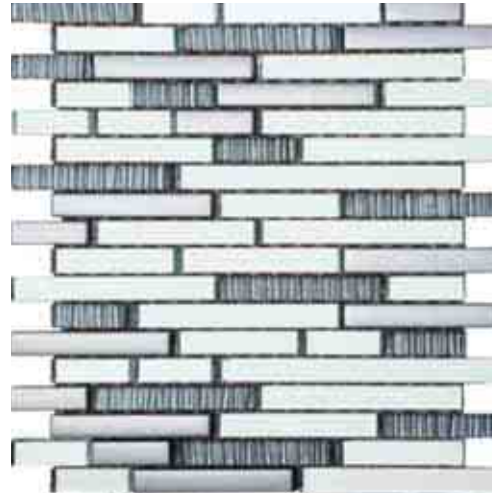

Reflections

30 x 30 cm
12"x 12"

Diamond



Luxury



Reflections



Elegance	Pcs/Caja Pcs/Box	m²/Caja m²/Box	Peso/Caja (Kg) Weight/Box	Caja/Palet Box/Pallet	m²/Palet m²/Pallet	Peso/Palet (Kg) Weight/Pallet
Diamond/Luxury	12	1,080	17,79	63	68,04	1121
Reflections	12	0,990	17,54	63	62,37	1105
	Pcs/Caja Pcs/Box	sq.ft./Caja sq.ft./Box	Peso/Caja Weight/Box(lb)	Caja/Palet Box/Pallet	sq.ft./Palet sq.ft./Pallet	Peso/Palet Weight/Pallet(lb)
Diamond/Luxury	12	11,63	39,22	63	732	2471
Reflections	12	10,66	38,67	63	671	2436

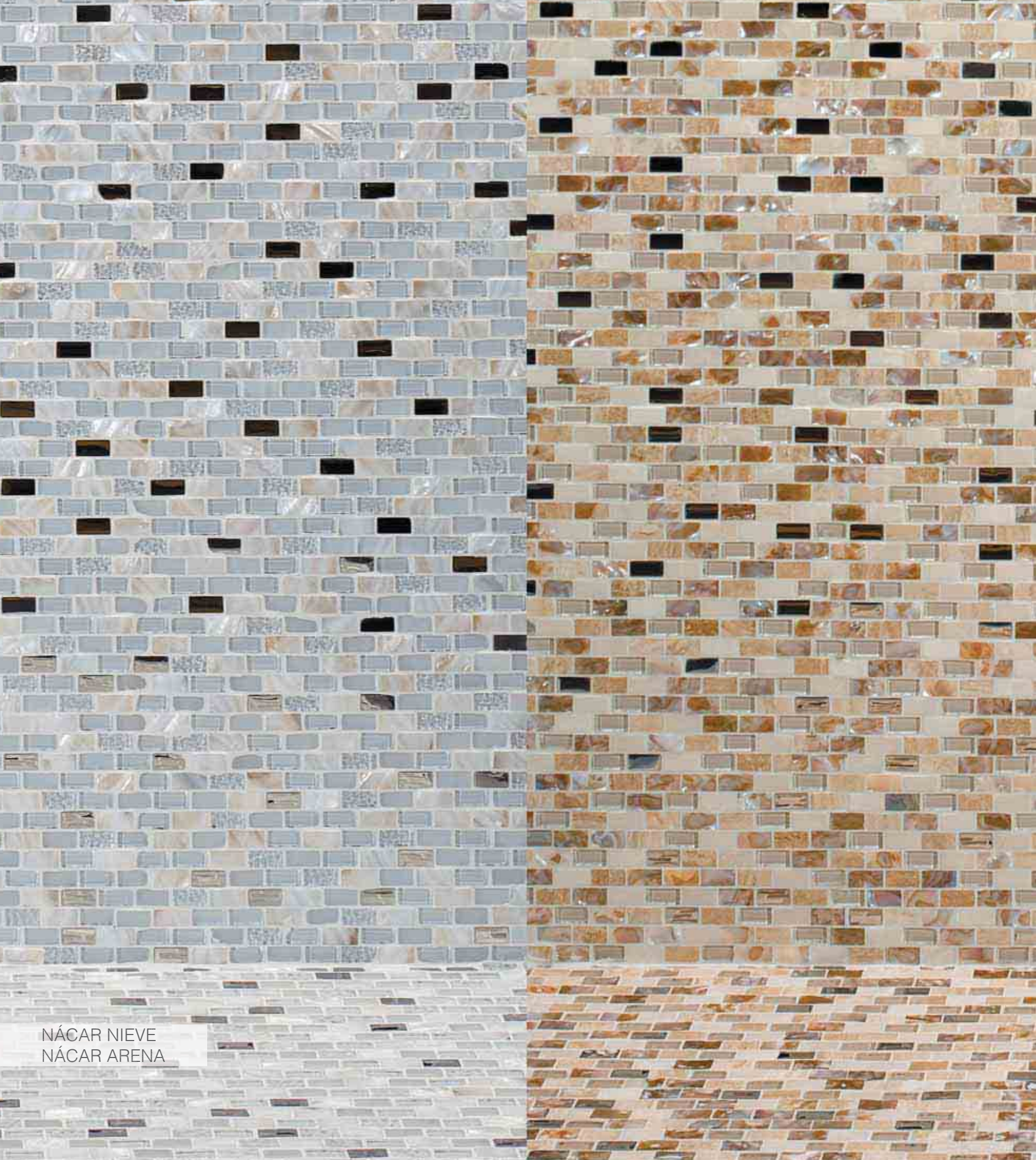

NÁCAR NIEVE
NÁCAR ARENA

Nácar

30 x 30 cm / 12"x 12"

MOSAIC



Nácar Abyss

30 x 30 cm
12"x 12"

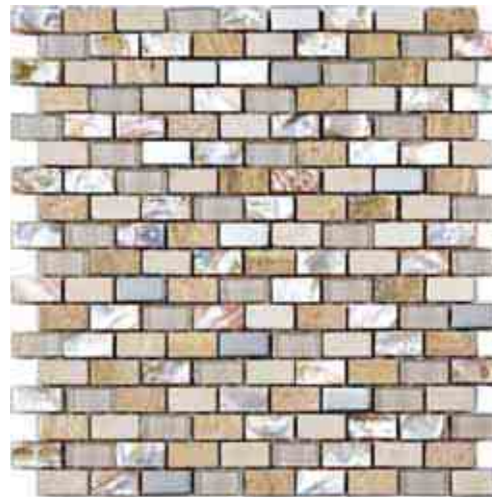

Nácar Arena

30 x 30 cm
12"x 12"



Nácar Nieve

30 x 30 cm
12"x 12"

ESSENTIA



REVESTIMIENTO
WALL TILES

MATE-BRILLO
MATT & SHINY

DESTONIFICADO
SHADE

MOSAICO EMALLADO
MESH MOSAIC

MARMOL
MARBLE

VIDRIO
GLASS

NÁCAR
MOTHER OF PEARL

Nácar	Pcs/Caja Pcs/Box	m ² /Caja m ² /Box	Peso/Caja (Kg) Weight/Box	Caja/Palet Box/Pallet	m ² /Palet m ² /Pallet	Peso/Palet (Kg) Weight/Pallet
	Pcs/Caja Pcs/Box	sq.ft./Caja sq.ft./Box	Peso/Caja Weight/Box(lb)	Caja/Palet Box/Pallet	sq.ft./Palet sq.ft./Pallet	Peso/Palet Weight/Pallet(lb)
	12	1,026	16,12	63	64,638	1016
	12	11,04	35,54	63	696	2239

PORCELAIN



MYKA BLACK

Myka

30 x 30 cm / 12"x 12"

MOSAIC



Myka Beige

30 x 30 cm
12"x 12"



Myka Black

30 x 30 cm
12"x 12"



REVESTIMIENTO
WALL TILES



MATE-BRILLO
MATT & SHINY



DESTONIFICADO
SHADE



RELIEVE
RELIEF



MOSADO EMALLADO
MESH MOSAIC



MARMOL
MARBLE



PIEDRA
NATURAL STONE



VIDRIO
GLASS

Myka	Pcs/Caja Pcs/Box	m ² /Caja m ² /Box	Peso/Caja (Kg) Weight/Box	Caja/Palet Box/Pallet	m ² /Palet m ² /Pallet	Peso/Palet (Kg) Weight/Pallet
	Pcs/Caja Pcs/Box	sq.ft./Caja sq.ft./Box	Peso/Caja Weight/Box(lb)	Caja/Palet Box/Pallet	sq.ft./Palet sq.ft./Pallet	Peso/Palet Weight/Pallet(lb)
	12	1,080	17,96	63	68,04	1131
	12	11,63	39,59	63	732	2494

PORCELAIN

ESSENTIA



PLANET GOLD



PLANET SILVER

Planet

30 x 30 cm / 12"x 12"

MOSAIC



Planet Gold

30 x 30 cm
12"x 12"

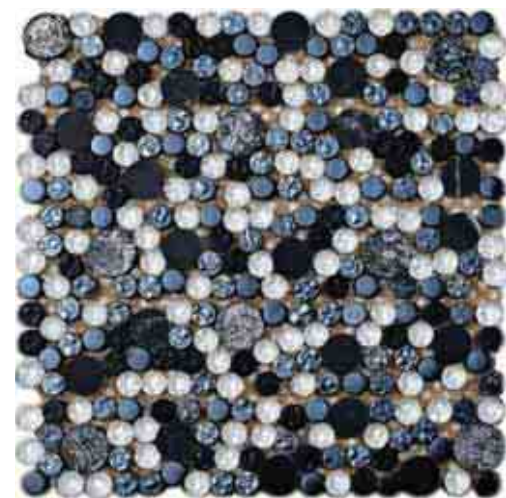

Planet Silver

30 x 30 cm
12"x 12"

ESSENTIA



REVESTIMIENTO
WALL TILES



MATE-BRILLO
MATT & SHINY



DESTONIFICADO
SHADE



MOSAICO EMALLADO
MESH MOSAIC



MARMOL
MARBLE



VIDRIO
GLASS

Planet	Pcs/Caja Pcs/Box	m ² /Caja m ² /Box	Peso/Caja (Kg) Weight/Box	Caja/Palet Box/Pallet	m ² /Palet m ² /Pallet	Peso/Palet (Kg) Weight/Pallet
	Pcs/Caja Pcs/Box	sq.ft./Caja sq.ft./Box	Peso/Caja Weight/Box(lb)	Caja/Palet Box/Pallet	sq.ft./Palet sq.ft./Pallet	Peso/Palet Weight/Pallet(lb)
	12	1,080	17,56	63	68,04	1106
	12	11,63	38,71	63	732	2439

PORCELAIN

Lagos

30 x 30 cm / 12"x 12"



Lagos Beige

30 x 30 cm
12"x 12"



Lagos Duna

30 x 30 cm
12"x 12"

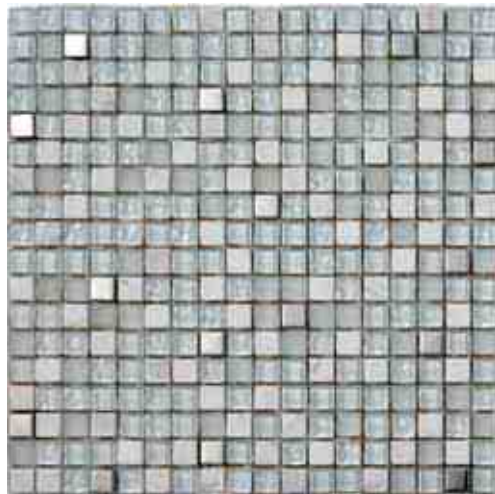

Lagos Glacier

30 x 30 cm
12"x 12"

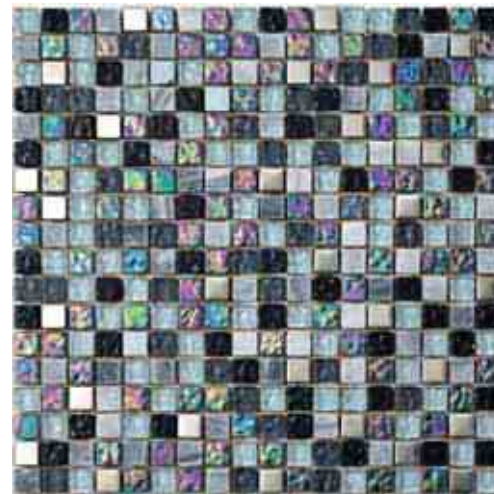

Lagos Kongo

30 x 30 cm
12"x 12"



REVESTIMIENTO
WALL TILES

MATE-BRILLO
MATT & SHINY

DESTONIFICADO
SHADE

RELIEVE
RELIEF

MOSAZO DIMALLADO
MESH MOSAIC

MARMOL
MARBLE

VIDRIO
GLASS

Lagos

30 x 30 cm / 12"x 12"

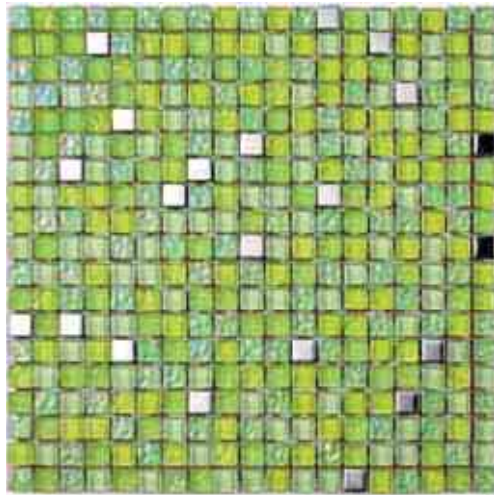

Lagos Lima

30 x 30 cm
12"x 12"

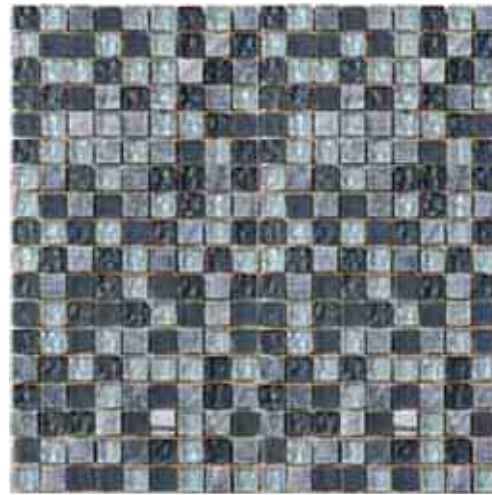

Lagos Negro

30 x 30 cm
12"x 12"



Lagos Night

30 x 30 cm
12"x 12"

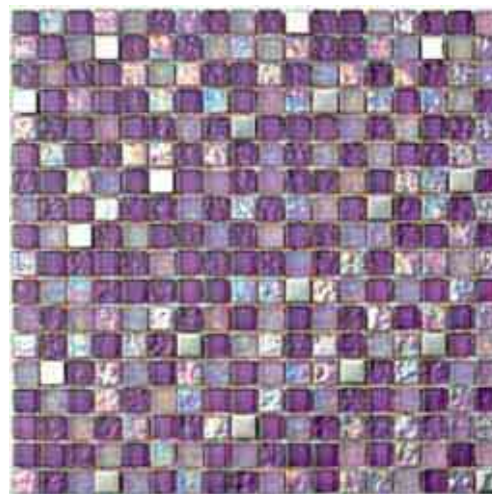

Lagos Persia

30 x 30 cm
12"x 12"

Lagos	Pcs/Caja	m ² /Caja	Peso/Caja (Kg)	Caja/Palet	m ² /Palet	Peso/Palet (Kg)	Pcs/Caja	sq.ft./Caja	Peso/Caja	Caja/Palet	sq.ft./Palet	Peso/Palet
	Pcs/Box	m ² /Box	Weight/Box	Box/Pallet	m ² /Pallet	Weight/Pallet	Pcs/Box	sq.ft./Box	Weight/Box(lb)	Box/Pallet	sq.ft./Pallet	Weight/Pallet(lb)
	12	1,080	17,47	63	68,04	1101	12	11,63	38,51	63	732	2426



LAGOS NIGHT



LAGOS BEIGE

Lagos

30 x 30 cm / 12"x 12"



Lagos Beige

30 x 30 cm
12"x 12"



Lagos Duna

30 x 30 cm
12"x 12"



Lagos Glacer

30 x 30 cm
12"x 12"



Lagos Night

30 x 30 cm
12"x 12"



Lagos	Pcs/Caja Pcs/Box	m ² /Caja m ² /Box	Peso/Caja (Kg) Weight/Box	Caja/Palet Box/Pallet	m ² /Palet m ² /Pallet	Peso/Palet (Kg) Weight/Pallet
	Pcs/Caja Pcs/Box	sq.ft./Caja sq.ft./Box	Peso/Caja Weight/Box(lb)	Caja/Palet Box/Pallet	sq.ft./Palet sq.ft./Pallet	Peso/Palet Weight/Pallet(lb)
	12	1,080	17,47	63	68,04	1101
	12	11,63	38,51	63	732	2426



LAGOS LIMA



LAGOS PERSIA

Lagos

30 x 30 cm / 12"x 12"

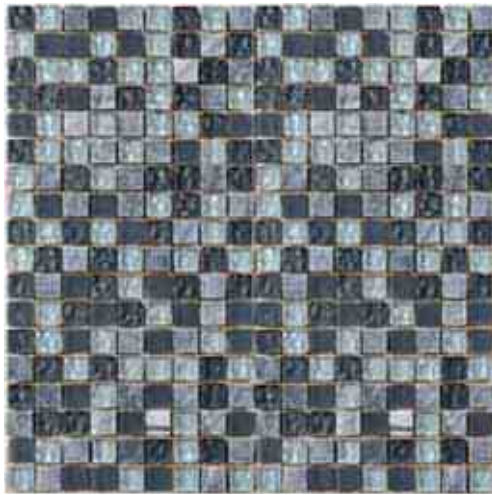

Lagos Negro

30 x 30 cm
12"x 12"

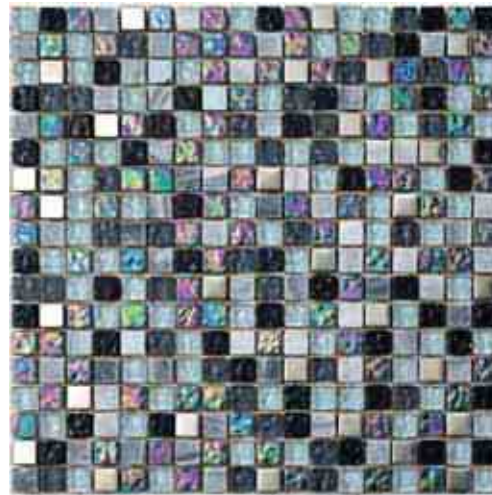

Lagos Kongo

30 x 30 cm
12"x 12"

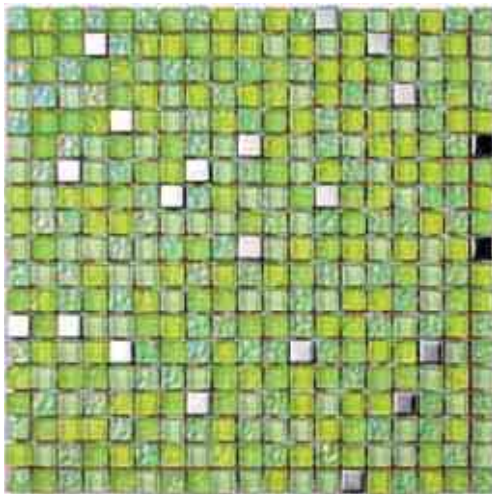

Lagos Lima

30 x 30 cm
12"x 12"

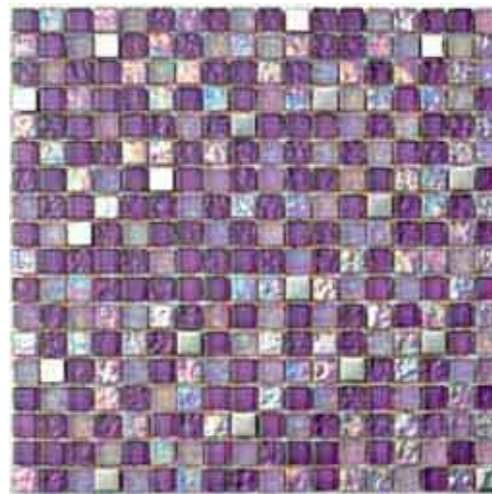

Lagos Persia

30 x 30 cm
12"x 12"



Lagos	Pcs/Caja Pcs/Box	m ² /Caja m ² /Box	Peso/Caja (Kg) Weight/Box	Caja/Palet Box/Pallet	m ² /Palet m ² /Pallet	Peso/Palet (Kg) Weight/Pallet
	Pcs/Caja Pcs/Box	sq.ft./Caja sq.ft./Box	Peso/Caja Weight/Box(lb)	Caja/Palet Box/Pallet	sq.ft./Palet sq.ft./Pallet	Peso/Palet Weight/Pallet(lb)
	12	1,080	17,47	63	68,04	1101
	12	11,63	38,51	63	732	2426



KUBICA NATURA

Kubica

30 x 30 cm / 12"x 12"



Kubica Natura

30 x 30 cm
12" x 12"



Kubica Onix

30 x 30 cm
12" x 12"



REVESTIMIENTO
WALL TILES



MATE-BRILLO
MATT & SHINY



DESTONIFICADO
SHADE



MOSICO EMALLADO
MESH MOSAC



IMARMOL
MARBLE



RESINA
RESIN



VIDRIO
GLASS

Kubica	Pcs/Caja Pcs/Box	m ² /Caja m ² /Box	Peso/Caja (Kg) Weight/Box	Caja/Palet Box/Pallet	m ² /Palet m ² /Pallet	Peso/Palet (Kg) Weight/Pallet
	Pcs/Caja Pcs/Box	sq.ft./Caja sq.ft./Box	Peso/Caja Weight/Box(lb)	Caja/Palet Box/Pallet	sq.ft./Palet sq.ft./Pallet	Peso/Palet Weight/Pallet(lb)
	12	1,080	19,40	63	68,04	1222
	12	11,63	42,77	63	732	2694



ARES

Glass

30 x 30 cm / 12"x 12"

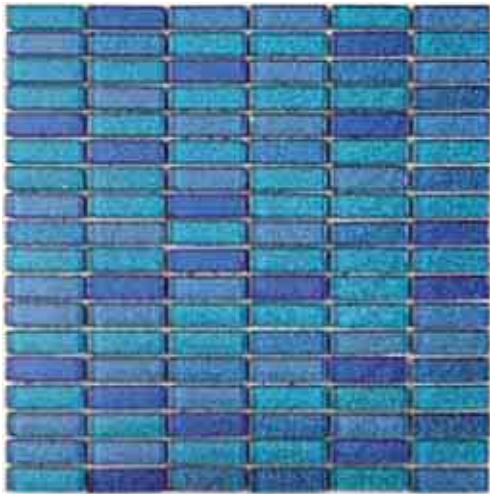

Glass Blue Sky

30 x 30 cm
12"x 12"

Forest

30 x 30 cm / 12"x 12"



Forest Wengué

30 x 30 cm
12"x 12"

Mármol

30 x 30 cm / 12"x 12"



Ares

30 x 30 cm
12"x 12"



Catí

30 x 30 cm
12"x 12"

Glass



Forest



Mármol



	Pcs/Caja Pcs/Box	m²/Caja m²/Box	Peso/Caja (Kg) Weight/Box	Caja/Palet Box/Pallet	m²/Palet m²/Pallet	Peso/Palet (Kg) Weight/Pallet
Glass	12	1,080	18,08	63	68,04	1139
Forest	12	1,080	16,81	63	68,04	1059
Mármol	12	1,080	17,68	63	68,04	1114
	Pcs/Caja Pcs/Box	sq.ft./Caja sq.ft./Box	Peso/Caja Weight/Box(lb)	Caja/Palet Box/Pallet	sq.ft./Palet sq.ft./Pallet	Peso/Palet Weight/Pallet(lb)
Glass	12	11,63	39,86	63	732	2511
Forest	12	11,63	37,06	63	732	2335
Mármol	12	11,63	38,98	63	732	2456



PERLA BIANCO NATURA

Perla

30 x 30 cm / 12"x 12"



Perla Bianco

30 x 30 cm
12"x 12"



Perla Bianco Natura

30 x 30 cm
12"x 12"



Perla Multicolor

30 x 30 cm
12"x 12"



Perla Nero

30 x 30 cm
12"x 12"



Perla Nero Natura

30 x 30 cm
12"x 12"

Perla	Pcs/Caja Pcs/Box	m ² /Caja m ² /Box	Peso/Caja (Kg) Weight/Box	Caja/Palet Box/Pallet	m ² /Palet m ² /Pallet	Peso/Palet (Kg) Weight/Pallet	
Bianco/Multicolor/Nero	11	0,990	26,10	54	53,46	1409	SIN BLISTER
Bianco Nat./Nero Nat.	11	0,990	19,80	54	53,46	1069	
Bianco/Multicolor/Nero	8	0,720	18,98	54	38,88	1025	BLISTER
Bianco Nat./Nero Nat.	8	0,720	14,40	54	38,88	778	
	Pcs/Caja Pcs/Box	sq.ft./Caja sq.ft./Box	Peso/Caja Weight/Box(lb)	Caja/Palet Box/Pallet	sq.ft./Palet sq.ft./Pallet	Peso/Palet Weight/Pallet(lb)	
Bianco/Multicolor/Nero	11	10,66	57,54	54	575	3107	SIN BLISTER
Bianco Nat./Nero Nat.	11	10,66	43,65	54	575	2357	
Bianco/Multicolor/Nero	8	7,75	41,84	54	419	2260	BLISTER
Bianco Nat./Nero Nat.	8	7,75	31,75	54	419	1714	





MATRIX ARENA

Matrix

30 x 30 cm / 12"x 12"

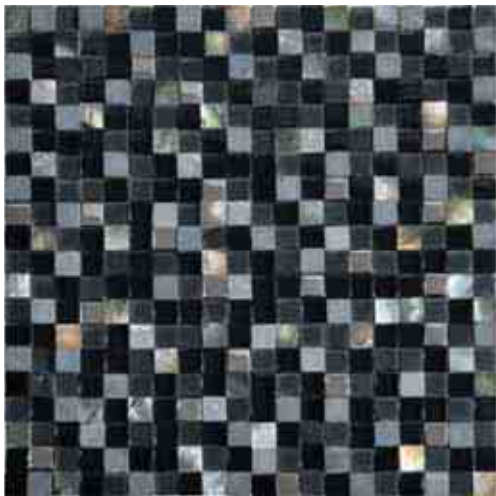

Matrix Abyss

30 x 30 cm
12"x 12"



Matrix Arena

30 x 30 cm
12"x 12"



Matrix Nieve

30 x 30 cm
12"x 12"



REVESTIMIENTO
WALL TILES



MATE-BRILLO
MATT & SHINY



DESTONIFICADO
SHADE



RELIEVE
RELIEF



MOSAICO ENMALLADO
MESH MOSAIC



MARMOL
MARBLE



VIDRIO
GLASS



NAJAR
MOTHER OF PEARL

Matrix	Pcs/Caja Pcs/Box	m ² /Caja m ² /Box	Peso/Caja (Kg) Weight/Box	Caja/Palet Box/Pallet	m ² /Palet m ² /Pallet	Peso/Palet (Kg) Weight/Pallet
	Pcs/Caja Pcs/Box	sq.ft./Caja sq.ft./Box	Peso/Caja Weight/Box(lb)	Caja/Palet Box/Pallet	sq.ft./Palet sq.ft./Pallet	Peso/Palet Weight/Pallet(lb)
	9	0,810	16,36	63	51,03	1031
	9	8,72	36,07	63	549	2272

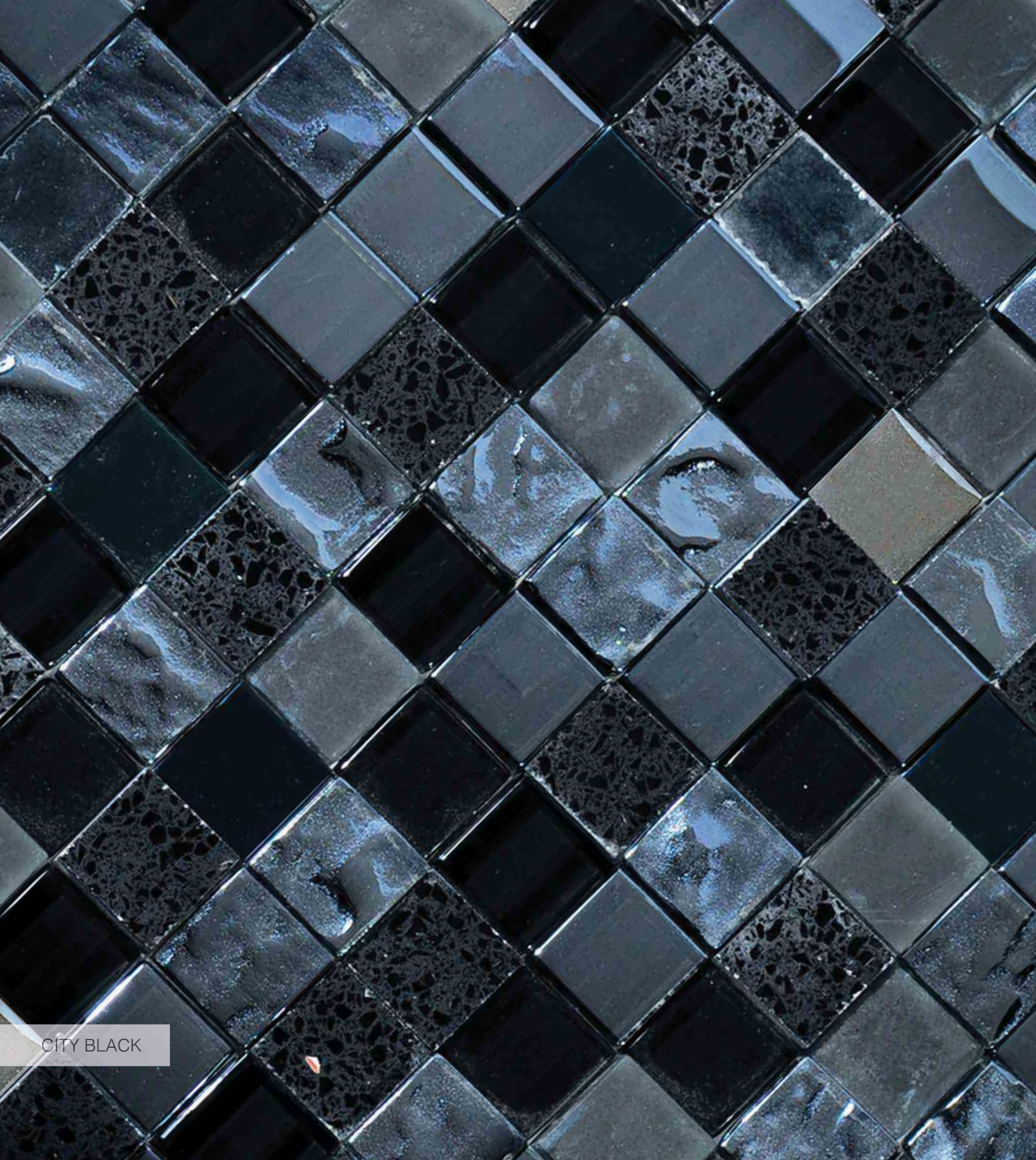

CITY BLACK

City

30 x 30 cm / 12"x 12"

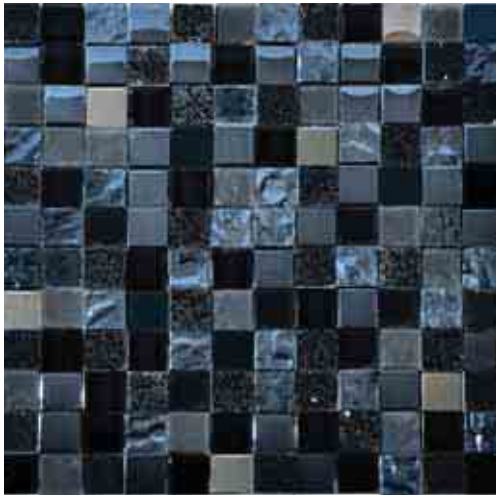

City Black

30 x 30 cm
12"x 12"



City Brown

30 x 30 cm
12"x 12"

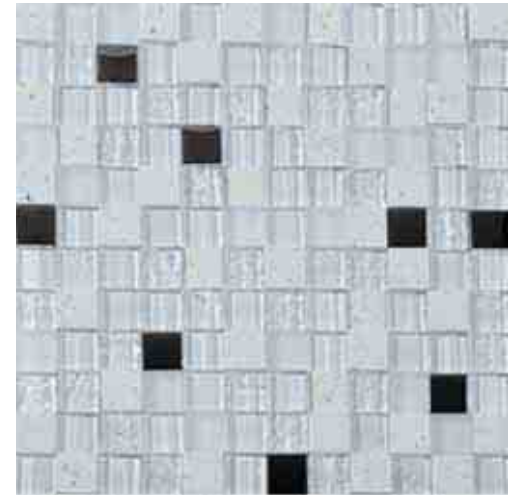

City White

30 x 30 cm
12"x 12"

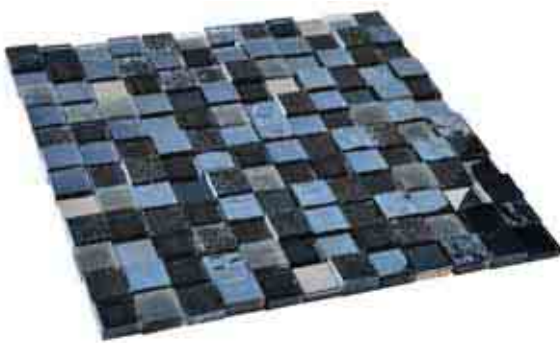

City	Pcs/Caja Pcs/Box	m ² /Caja m ² /Box	Peso/Caja (Kg) Weight/Box	Caja/Palet Box/Pallet	m ² /Palet m ² /Pallet	Peso/Palet (Kg) Weight/Pallet
	Pcs/Caja Pcs/Box	sq.ft./Caja sq.ft./Box	Peso/Caja Weight/Box(lb)	Caja/Palet Box/Pallet	sq.ft./Palet sq.ft./Pallet	Peso/Palet Weight/Pallet(lb)
	9	0,826	19,76	63	52,038	1245
	9	8,89	43,56	63	560	2744



CUBIK BEIGE

Cubik

30 x 30 cm / 12"x 12"

MOSAIC



Cubik Beige

30 x 30 cm
12"x 12"

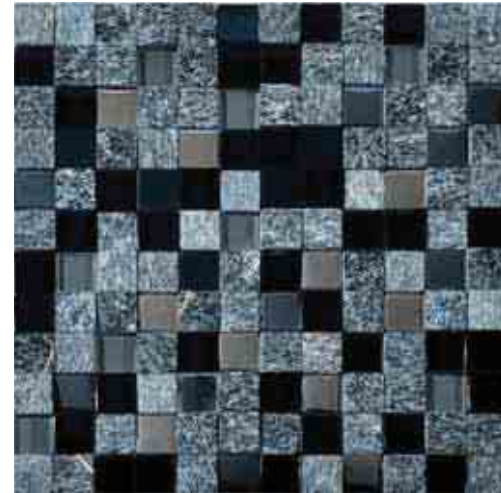

Cubik Beige

30 x 30 cm
12"x 12"



ESSENTIA



REVESTIMIENTO
WALL TILES

MATE-BRILLO
MATT & SHINY

DESTONIFICADO
SHADE

RELIEVE
RELIEF

MOSACO ENMALLADO
MESH MOSAIC

PIEDRA
NATURAL STONE

VIDRIO
GLASS

Cubik	Pcs/Caja Pcs/Box	m ² /Caja m ² /Box	Peso/Caja (Kg) Weight/Box	Caja/Palet Box/Pallet	m ² /Palet m ² /Pallet	Peso/Palet (Kg) Weight/Pallet
	Pcs/Caja Pcs/Box	sq.ft./Caja sq.ft./Box	Peso/Caja Weight/Box(lb)	Caja/Palet Box/Pallet	sq.ft./Palet sq.ft./Pallet	Peso/Palet Weight/Pallet(lb)
	9	0,826	21,30	63	52,038	1342
	9	8,89	46,96	63	560	2958

PORCELAIN



DECO PETRA AVORIO MARE

Petra

10 x 40 cm / 4" x 16"

MOSAIC

ESSENTIA

PORCELAIN



DECO PETRA OSSIDO RUGGINE



Petra

10 x 40 cm / 4" x 16"



MOSAIC

ESSENTIA

PORCELAIN

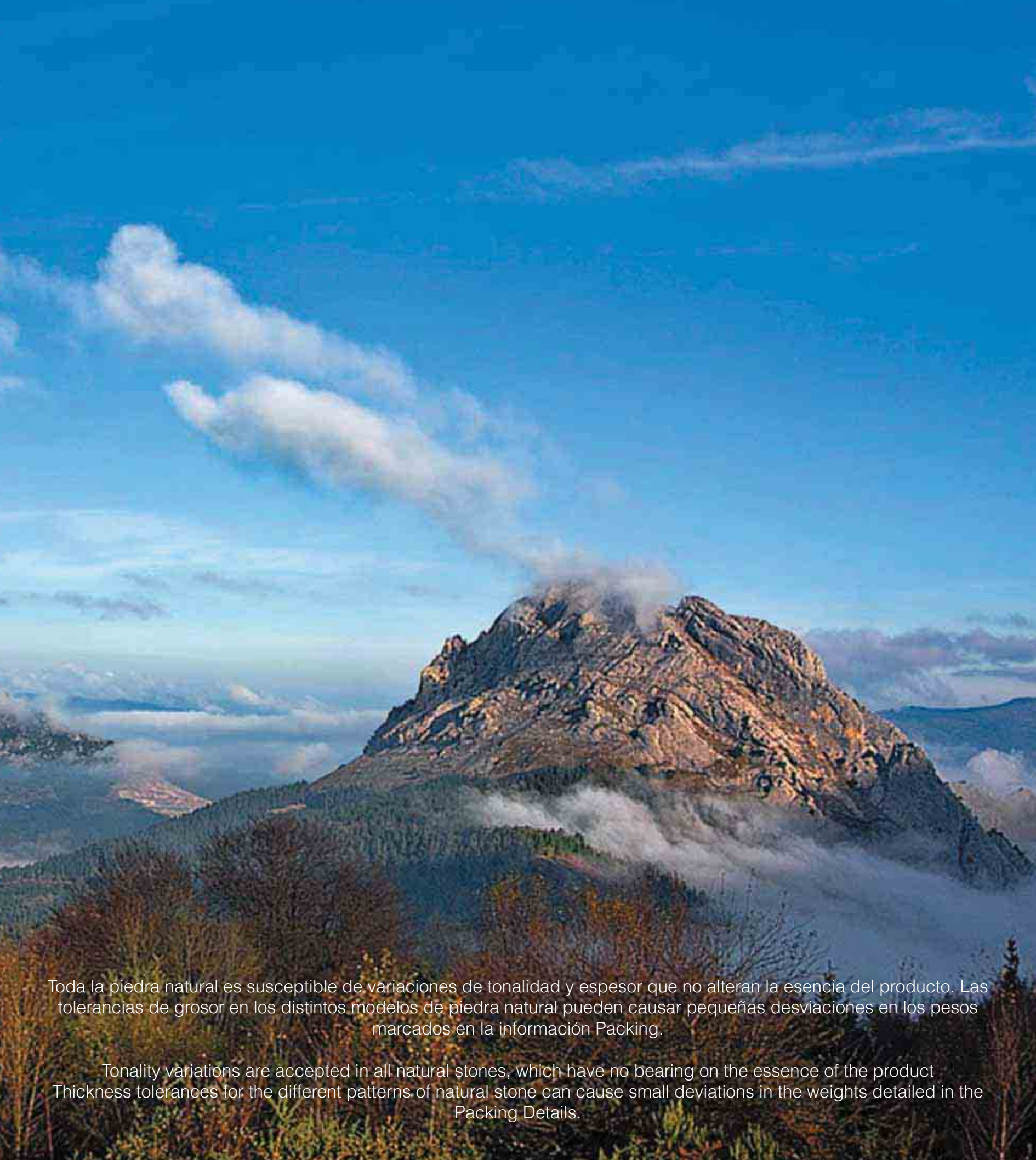

Toda la piedra natural es susceptible de variaciones de tonalidad y espesor que no alteran la esencia del producto. Las tolerancias de grosor en los distintos modelos de piedra natural pueden causar pequeñas desviaciones en los pesos marcados en la información Packing.

Tonality variations are accepted in all natural stones, which have no bearing on the essence of the product. Thickness tolerances for the different patterns of natural stone can cause small deviations in the weights detailed in the Packing Details.

Petra

10 x 40 cm / 4" x 16"

Petra
Avorio



Petra
Grigio

Deco Petra
Avorio
Dune



Deco Petra
Grigio
Cenere

Deco Petra
Avorio
Mare



Deco Petra
Grigio
Foglia

Petra
Bianco



Petra Nero

Deco Petra
Bianco
Argento



Deco Petra
Nero Allum

Deco Petra
Bianco
Quadro



Deco
Petra Nero
Nebbia

Petra
Ossido



Deco Petra
Nero Notte

Deco Petra
Ossido
Marrone



Petra
Vulcano
(Sellado/
Sealed)

Deco Petra
Ossido
Ruggine





PETRA AVORIO MARE

Petra

10 x 40 cm / 4" x 16"



Petra Avorio

10 x 40 cm
4" x 16"



Deco Petra Avorio Dune

10 x 40 cm
4" x 16"



Deco Petra Avorio Mare

10 x 40 cm
4" x 16"



Panel Petra Avorio



Panel Deco Petra Avorio Mare



Panel Deco Petra Avorio Dune



Panel Deco Petra Avorio Mix

Petra



Petra Deco

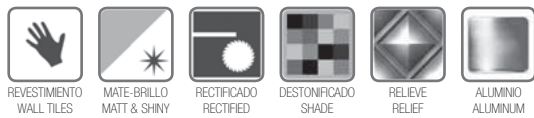

	Pcs/Caja Pcs/Box	m ² /Caja m ² /Box	Peso/Caja (Kg) Weight/Box	Caja/Palet Box/Pallet	m ² /Palet m ² /Pallet	Peso/Palet (Kg) Weight/Pallet
Petra	12	0,480	13,50	96	46,08	1296
Deco Petra	10	0,400	11,50	96	38,4	1104
	Pcs/Caja Pcs/Box	sq.ft./Caja sq.ft./Box	Peso/Caja Weight/Box(lb)	Caja/Palet Box/Pallet	sq.ft./Palet sq.ft./Pallet	Peso/Palet Weight/Pallet(lb)
Petra	12	5,17	29,76	96	496	2857
Deco Petra	10	4,31	25,35	96	413	2434



PETRA BIANCO

Petra

10 x 40 cm / 4" x 16"



Petra Bianco

10 x 40 cm
4" x 16"



Deco Petra Bianco Argento

10 x 40 cm
4" x 16"



Deco Petra Bianco Quadro

10 x 40 cm
4" x 16"



Panel Petra Bianco



Panel Deco Petra Bianco Quadro



Panel Deco Petra Bianco Argento



Panel Deco Petra Bianco Mix

Petra



Petra Deco



	Pcs/Caja Pcs/Box	m ² /Caja m ² /Box	Peso/Caja (Kg) Weight/Box	Caja/Palet Box/Pallet	m ² /Palet m ² /Pallet	Peso/Palet (Kg) Weight/Pallet
Petra	12	0,480	13,50	96	46,08	1296
Deco Petra	10	0,400	11,50	96	38,4	1104
	Pcs/Caja Pcs/Box	sq.ft./Caja sq.ft./Box	Peso/Caja Weight/Box(lb)	Caja/Palet Box/Pallet	sq.ft./Palet sq.ft./Pallet	Peso/Palet Weight/Pallet(lb)
Petra	12	5,17	29,76	96	496	2857
Deco Petra	10	4,31	25,35	96	413	2434



PETRA GRIGIO CENERE

Petra

10 x 40 cm / 4" x 16"



Petra Grigio

10 x 40 cm
4" x 16"



Deco Petra Grigio Cenere

10 x 40 cm
4" x 16"



Deco Petra Grigio Foglia

10 x 40 cm
4" x 16"



Panel Petra Grigio



Panel Deco Petra Grigio Foglia



Panel Deco Petra Grigio Cenere



Panel Deco Petra Grigio Mix

Petra



Petra Deco



	Pcs/Caja Pcs/Box	m ² /Caja m ² /Box	Peso/Caja (Kg) Weight/Box	Caja/Palet Box/Pallet	m ² /Palet m ² /Pallet	Peso/Palet (Kg) Weight/Pallet
Petra	12	0,480	13,50	96	46,08	1296
Deco Petra	10	0,400	11,50	96	38,4	1104
	Pcs/Caja Pcs/Box	sq.ft./Caja sq.ft./Box	Peso/Caja Weight/Box(lb)	Caja/Palet Box/Pallet	sq.ft./Palet sq.ft./Pallet	Peso/Palet Weight/Pallet(lb)
Petra	12	5,17	29,76	96	496	2857
Deco Petra	10	4,31	25,35	96	413	2434



PETRA NERO NEBBIA

Petra

10 x 40 cm / 4" x 16"



Petra Nero

10 x 40 cm
4" x 16"



Deco Petra Nero Allum

10 x 40 cm
4" x 16"



Deco Petra Nero Nebbia

10 x 40 cm
4" x 16"



Deco Petra Nero Notte

10 x 40 cm
4" x 16"



Panel Petra Nero



Panel Deco Petra Nero Notte



Petra Vulcano
(Sellado/Sealed)

10 x 40 cm
4" x 16"



Panel Deco Petra Nero Allum

Petra



Petra Deco



Petra Nero: Contiene partículas metálicas que en determinadas condiciones de humedad pueden oxidarse.

Petra Nero: Contains metal particles that in some humidity conditions may get stained.

	Pcs/Caja Pcs/Box	m ² /Caja m ² /Box	Peso/Caja (Kg) Weight/Box	Caja/Palet Box/Pallet	m ² /Palet m ² /Pallet	Peso/Palet (Kg) Weight/Pallet
Petra	12	0,480	13,50	96	46,08	1296
Deco Petra	10	0,400	11,50	96	38,4	1104
	Pcs/Caja Pcs/Box	sq.ft./Caja sq.ft./Box	Peso/Caja Weight/Box(lb)	Caja/Palet Box/Pallet	sq.ft./Palet sq.ft./Pallet	Peso/Palet Weight/Pallet(lb)
Petra	12	5,17	29,76	96	496	2857
Deco Petra	10	4,31	25,35	96	413	2434



PETRA OSSIDO

Petra

10 x 40 cm / 4" x 16"



Petra Ossido

10 x 40 cm
4" x 16"



Deco Petra Ossido Marrone

10 x 40 cm
4" x 16"



Deco Petra Ossido Ruggine

10 x 40 cm
4" x 16"



Panel Petra Ossido



Panel Deco Petra Ossido Ruggine



Panel Deco Petra Ossido Marrone



Panel Deco Petra Ossido Mix

Petra



Petra Deco

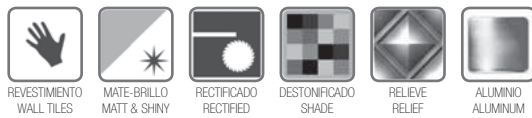

	Pcs/Caja Pcs/Box	m ² /Caja m ² /Box	Peso/Caja (Kg) Weight/Box	Caja/Palet Box/Pallet	m ² /Palet m ² /Pallet	Peso/Palet (Kg) Weight/Pallet
Petra	12	0,480	13,50	96	46,08	1296
Deco Petra	10	0,400	11,50	96	38,4	1104
	Pcs/Caja Pcs/Box	sq.ft./Caja sq.ft./Box	Peso/Caja Weight/Box(lb)	Caja/Palet Box/Pallet	sq.ft./Palet sq.ft./Pallet	Peso/Palet Weight/Pallet(lb)
Petra	12	5,17	29,76	96	496	2857
Deco Petra	10	4,31	25,35	96	413	2434



CEMENTI GRAFITO

Cementi

10 x 10 - 20 x 20 - 33 x 33 - 30 x 60 - 60 x 60 cm / 4"x 4" - 8"x 8" - 13"x 13" - 12"x 24" - 24"x 24"

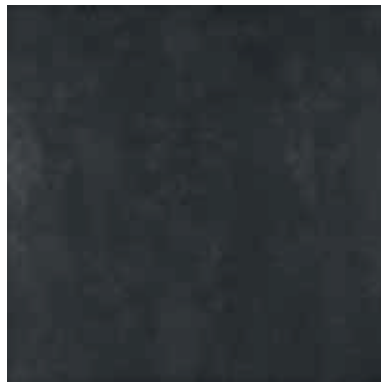

60 x 60 cm
24"x 24"



30 x 60 cm
12"x 24"



20 x 20 cm
8"x 8"

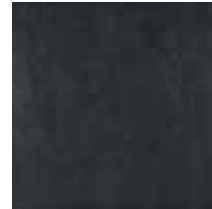

33 x 33 cm
13"x 13"



10 x 10 - 30 x 40 cm
12"x 16"

CEMENTI GRAFITO

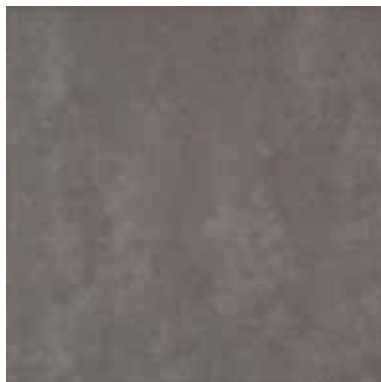

60 x 60 cm
24"x 24"

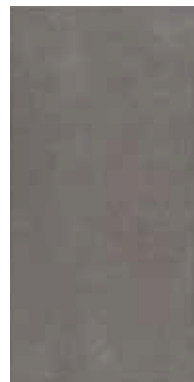

30 x 60 cm
12"x 24"

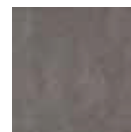

20 x 20 cm
8"x 8"

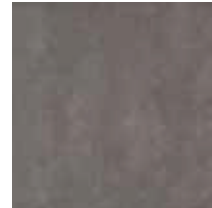

33 x 33 cm
13"x 13"



10 x 10 - 30 x 40 cm
12"x 16"

CEMENTI GRIS



60 x 60 cm
24"x 24"



30 x 60 cm
12"x 24"



20 x 20 cm
8"x 8"



33 x 33 cm
13"x 13"



10 x 10 - 30 x 40 cm
12"x 16"

CEMENTI IVORY

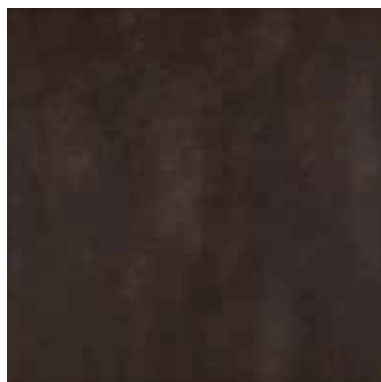

60 x 60 cm
24"x 24"



30 x 60 cm
12"x 24"



20 x 20 cm
8"x 8"

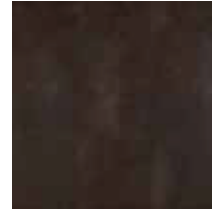

33 x 33 cm
13"x 13"



10 x 10 - 30 x 40 cm
12"x 16"

CEMENTI OXO

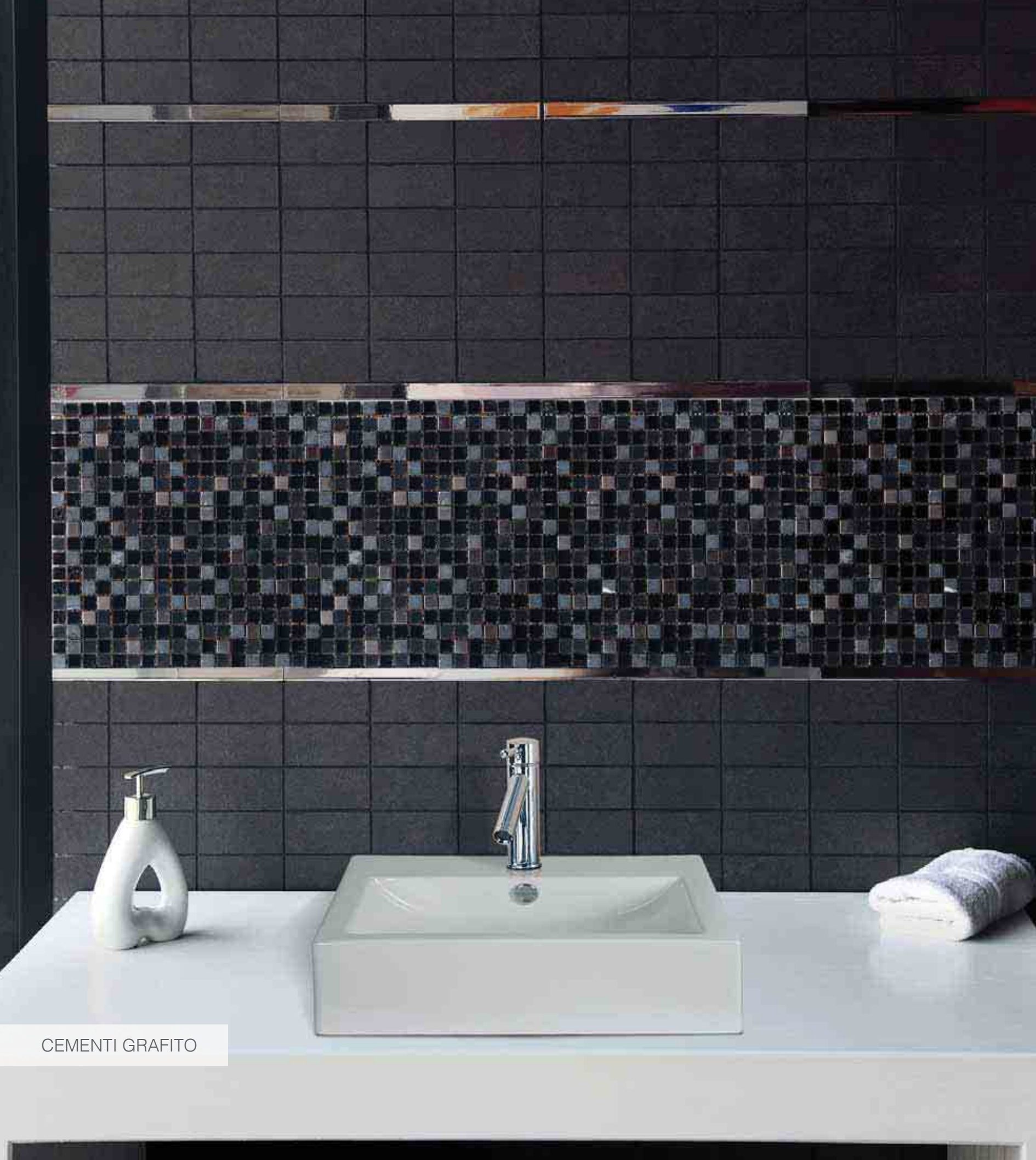

CEMENTI GRAFITO

Cementi

10 x 10 - 20 x 20 - 33 x 33 - 30 x 60 - 60 x 60 cm / 4"x 4" - 8"x 8" - 13"x 13" - 12"x 24" - 24"x 24"



Cementi Grafito 60 x 60 cm
24"x 24"

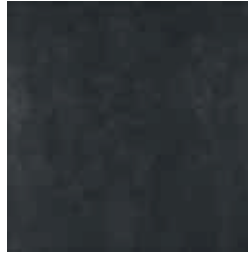

Cementi Grafito 33 x 33 cm
13"x 13"

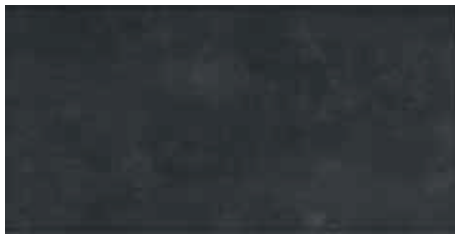

Cementi Grafito 30 x 60 cm
12"x 24"



Cementi Grafito 10x10 30 x 40 cm
12"x 16"



Cementi Grafito 20 x 20 cm
8"x 8"

10 x 10 cm
20 x 20 cm



PANIMENTO PESTAMENTO
WALL & FLOOR TILES



MATE
MATT



ESMALTADO
GLAZED



IMPRESIÓN DIGITAL
DIGITAL PRINTING

33 x 33 cm
30 x 60 cm
60 x 60 cm



PANIMENTO PESTAMENTO
WALL & FLOOR TILES



MATE
MATT



PORCELÁNICO
PORCELAIN



ESMALTADO
GLAZED



IMPRESIÓN DIGITAL
DIGITAL PRINTING

Cementi	Pcs/Caja Pcs/Box	m ² /Caja m ² /Box	Peso/Caja (Kg) Weight/Box	Caja/Palet Box/Pallet	m ² /Palet m ² /Pallet	Peso/Palet (Kg) Weight/Pallet
10 x 10	12	1,440	20,48	54	77,76	1106
20 x 20 cm	25	1,000	14,70	96	96	1411
33 x 33 cm	15	1,640	26,60	46	75,44	1224
30 x 60 cm	6	1,080	22,88	40	43,2	915
60 x 60 cm	4	1,440	31,88	30	43,2	956
	Pcs/Caja Pcs/Box	sq.ft./Caja sq.ft./Box	Peso/Caja Weight/Box(lb)	Caja/Palet Box/Pallet	sq.ft./Palet sq.ft./Pallet	Peso/Palet Weight/Pallet(lb)
4"x 4"	12	15,50	45,15	54	837	2438
8"x 8"	25	10,76	32,41	96	1033	3111
13"x 13"	15	17,65	58,64	46	812	2698
12"x 24"	6	11,63	50,44	40	465	2018
24"x 24"	4	15,50	70,28	30	465	2108



CEMENTI GRIS

Cementi

10 x 10 - 20 x 20 - 33 x 33 - 30 x 60 - 60 x 60 cm / 4"x 4" - 8"x 8" - 13"x 13" - 12"x 24" - 24"x 24"



Cementi Gris 60 x 60 cm
24"x 24"

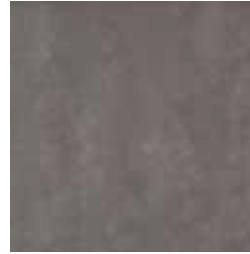

Cementi Gris 33 x 33 cm
13"x 13"

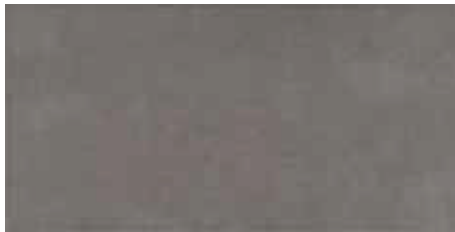

Cementi Gris 30 x 60 cm
12"x 24"



Cementi Gris 10x10
30 x 40 cm
12"x 16"

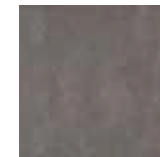

Cementi Gris 20 x 20 cm
8"x 8"

10 x 10 cm
20 x 20 cm



PARED/REVESTIMIENTO
WALL & FLOOR TILES



MATE
MATT



ESMALTADO
GLAZED



IMPRESIÓN DIGITAL
DIGITAL PRINTING

33 x 33 cm
30 x 60 cm
60 x 60 cm



PARED/REVESTIMIENTO
WALL & FLOOR TILES



MATE
MATT



PORCELÁNICO
PORCELAIN



ESMALTADO
GLAZED



IMPRESIÓN DIGITAL
DIGITAL PRINTING

Cementi	Pcs/Caja Pcs/Box	m ² /Caja m ² /Box	Peso/Caja (Kg) Weight/Box	Caja/Palet Box/Pallet	m ² /Palet m ² /Pallet	Peso/Palet (Kg) Weight/Pallet
10 x 10	12	1,440	20,48	54	77,76	1106
20 x 20 cm	25	1,000	14,70	96	96	1411
33 x 33 cm	15	1,640	26,60	46	75,44	1224
30 x 60 cm	6	1,080	22,88	40	43,2	915
60 x 60 cm	4	1,440	31,88	30	43,2	956
	Pcs/Caja Pcs/Box	sq.ft./Caja sq.ft./Box	Peso/Caja Weight/Box(lb)	Caja/Palet Box/Pallet	sq.ft./Palet sq.ft./Pallet	Peso/Palet Weight/Pallet(lb)
4"x 4"	12	15,50	45,15	54	837	2438
8"x 8"	25	10,76	32,41	96	1033	3111
13"x 13"	15	17,65	58,64	46	812	2698
12"x 24"	6	11,63	50,44	40	465	2018
24"x 24"	4	15,50	70,28	30	465	2108

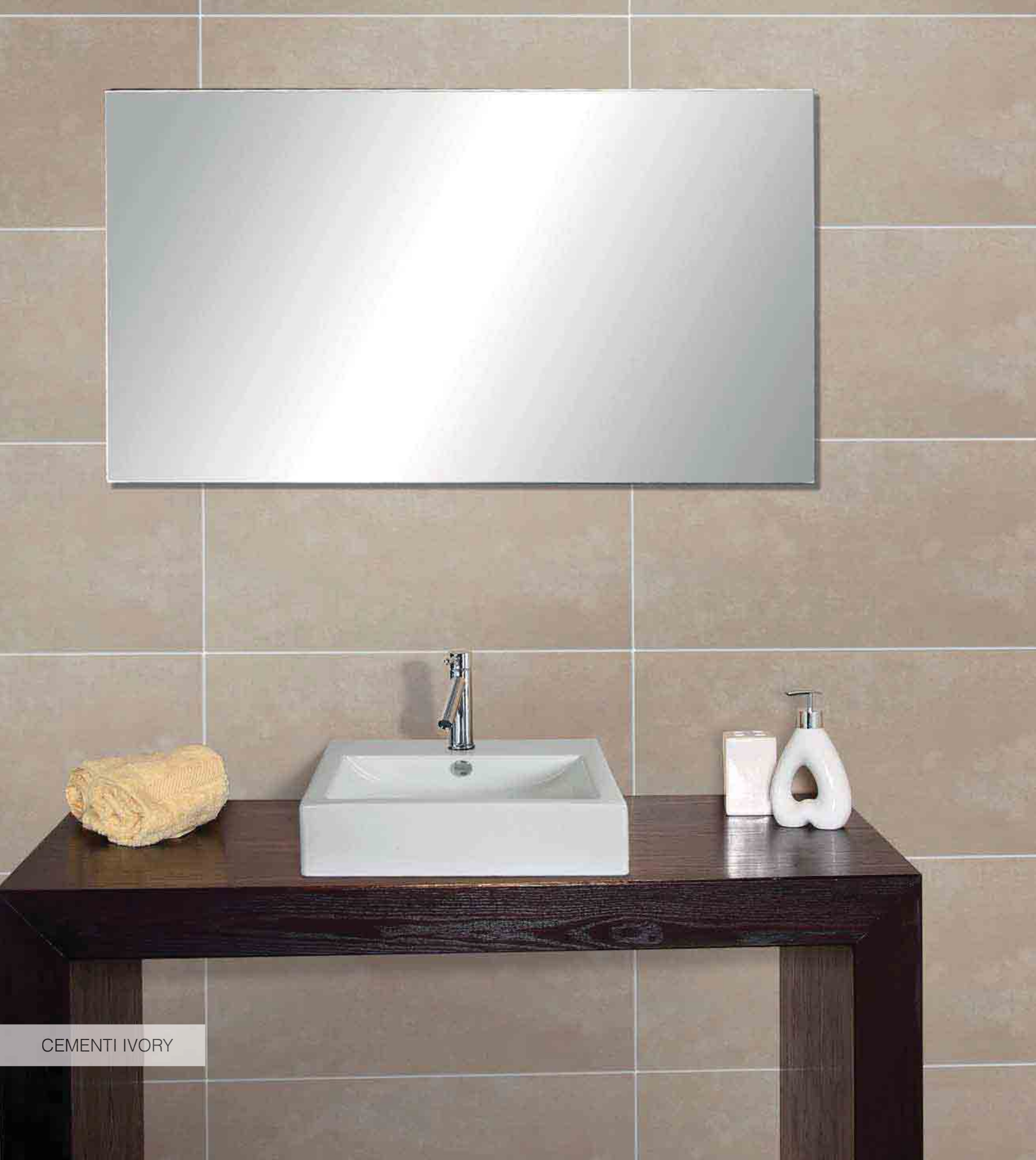

CEMENTI IVORY

Cementi

10 x 10 - 20 x 20 - 33 x 33 - 30 x 60 - 60 x 60 cm / 4"x 4" - 8"x 8" - 13"x 13" - 12"x 24" - 24"x 24"



Cementi Ivory 60 x 60 cm
24"x 24"

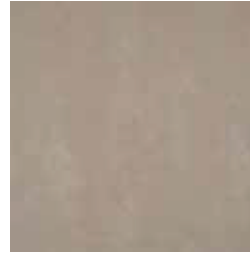

Cementi Ivory 33 x 33 cm
13"x 13"

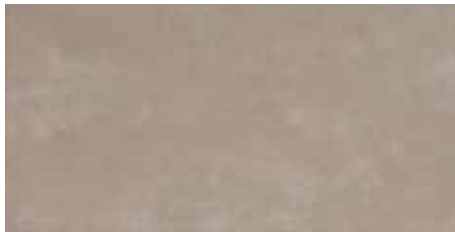

Cementi Ivory 30 x 60 cm
12"x 24"



Cementi Ivory 10x10
30 x 40 cm
12"x 16"



Cementi Ivory 20 x 20 cm
8"x 8"

10 x 10 cm
20 x 20 cm



PARED/REVESTIMIENTO
WALL & FLOOR TILES



MATE
MATT



ESMALTADO
GLAZED



IMPRESIÓN DIGITAL
DIGITAL PRINTING

33 x 33 cm
30 x 60 cm
60 x 60 cm



PARED/REVESTIMIENTO
WALL & FLOOR TILES



MATE
MATT



PORCELÁNICO
PORCELAIN



ESMALTADO
GLAZED



IMPRESIÓN DIGITAL
DIGITAL PRINTING

Cementi	Pcs/Caja Pcs/Box	m ² /Caja m ² /Box	Peso/Caja (Kg) Weight/Box	Caja/Palet Box/Pallet	m ² /Palet m ² /Pallet	Peso/Palet (Kg) Weight/Pallet
10 x 10	12	1,440	20,48	54	77,76	1106
20 x 20 cm	25	1,000	14,70	96	96	1411
33 x 33 cm	15	1,640	26,60	46	75,44	1224
30 x 60 cm	6	1,080	22,88	40	43,2	915
60 x 60 cm	4	1,440	31,88	30	43,2	956
	Pcs/Caja Pcs/Box	sq.ft./Caja sq.ft./Box	Peso/Caja Weight/Box(lb)	Caja/Palet Box/Pallet	sq.ft./Palet sq.ft./Pallet	Peso/Palet Weight/Pallet(lb)
4"x 4"	12	15,50	45,15	54	837	2438
8"x 8"	25	10,76	32,41	96	1033	3111
13"x 13"	15	17,65	58,64	46	812	2698
12"x 24"	6	11,63	50,44	40	465	2018
24"x 24"	4	15,50	70,28	30	465	2108



CEMENTI OXO

Cementi

10 x 10 - 20 x 20 - 33 x 33 - 30 x 60 - 60 x 60 cm / 4"x 4" - 8"x 8" - 13"x 13" - 12"x 24" - 24"x 24"



Cementi Oxo 60 x 60 cm
24"x 24"

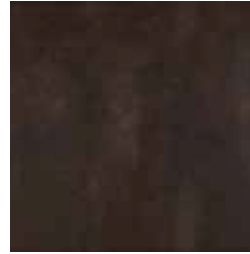

Cementi Oxo
33 x 33 cm
13"x 13"

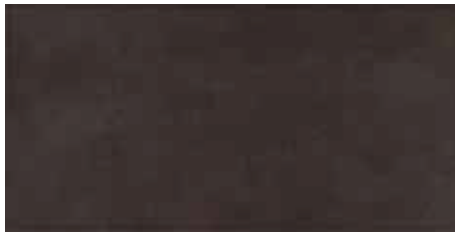

Cementi Oxo 30 x 60 cm
12"x 24"



Cementi Oxo 10x10
30 x 40 cm
12"x 16"



Cementi Oxo
20 x 20 cm
8"x 8"

10 x 10 cm
20 x 20 cm



PARED/REVESTIMIENTO
WALL & FLOOR TILES



MATE
MATT



ESMALTADO
GLAZED



IMPRESIÓN DIGITAL
DIGITAL PRINTING

33 x 33 cm
30 x 60 cm
60 x 60 cm



PARED/REVESTIMIENTO
WALL & FLOOR TILES



MATE
MATT



PORCELÁNICO
PORCELAIN



ESMALTADO
GLAZED



IMPRESIÓN DIGITAL
DIGITAL PRINTING

Cementi	Pcs/Caja Pcs/Box	m ² /Caja m ² /Box	Peso/Caja (Kg) Weight/Box	Caja/Palet Box/Pallet	m ² /Palet m ² /Pallet	Peso/Palet (Kg) Weight/Pallet
10 x 10	12	1,440	20,48	54	77,76	1106
20 x 20 cm	25	1,000	14,70	96	96	1411
33 x 33 cm	15	1,640	26,60	46	75,44	1224
30 x 60 cm	6	1,080	22,88	40	43,2	915
60 x 60 cm	4	1,440	31,88	30	43,2	956
	Pcs/Caja Pcs/Box	sq.ft./Caja sq.ft./Box	Peso/Caja Weight/Box(lb)	Caja/Palet Box/Pallet	sq.ft./Palet sq.ft./Pallet	Peso/Palet Weight/Pallet(lb)
4"x 4"	12	15,50	45,15	54	837	2438
8"x 8"	25	10,76	32,41	96	1033	3111
13"x 13"	15	17,65	58,64	46	812	2698
12"x 24"	6	11,63	50,44	40	465	2018
24"x 24"	4	15,50	70,28	30	465	2108



STRATO NATURALE

Strato

5 x 5 - 10 x 10 - 30 x 60 cm / 2"x 2" - 4"x 4" - 12"x 24"



Strato Naturale C2 30 x 60 cm
12"x 24"



Strato Chiaro C2 30 x 60 cm
12"x 24"



Strato Grafito C2 30 x 60 cm
12"x 24"



Strato Grigio C2 30 x 60 cm
12"x 24"



Strato	Pcs/Caja Pcs/Box	m ² /Caja m ² /Box	Peso/Caja (Kg) Weight/Box	Caja/Palet Box/Pallet	m ² /Palet m ² /Pallet	Peso/Palet (Kg) Weight/Pallet
	Pcs/Caja Pcs/Box	sq.ft./Caja sq.ft./Box	Peso/Caja Weight/Box(lb)	Caja/Palet Box/Pallet	sq.ft./Palet sq.ft./Pallet	Peso/Palet Weight/Pallet(lb)
	6	1,100	23,75	40	44	950
	6	11,84	52,36	40	474	2094



STRATO

Strato

5 x 5 - 10 x 10 - 30 x 60 cm / 2"x 2" - 4"x 4" - 12"x 24"



Strato Naturale 10x10
30 x 30 cm
12"x 12"



Strato Chiaro 10x10
30 x 30 cm
12"x 12"



Strato Grafito 10x10
30 x 30 cm
12"x 12"



Strato Grigio 10x10
30 x 30 cm
12"x 12"



Strato Terra 5x5
30 x 30 cm
12"x 12"



Strato Note 5x5
30 x 30 cm
12"x 12"



Strato Grafito Muretto
30 x 30 cm
12"x 12"



Strato Grigio Muretto
30 x 30 cm
12"x 12"



Strato	Pcs/Caja Pcs/Box	m²/Caja m²/Box	Peso/Caja (Kg) Weight/Box	Caja/Palet Box/Pallet	m²/Palet m²/Pallet	Peso/Palet (Kg) Weight/Pallet
5 x 5	11	0,990	18,95	48	47,52	910
10 x 10	11	0,990	19,94	48	47,52	957
Muretto 30 x 30 cm	11	0,990	19,11	30	29,7	573
	Pcs/Caja Pcs/Box	sq.ft./Caja sq.ft./Box	Peso/Caja Weight/Box(lb)	Caja/Palet Box/Pallet	sq.ft./Palet sq.ft./Pallet	Peso/Palet Weight/Pallet(lb)
2"x 2"	11	10,66	41,78	48	512	2006
4"x 4"	11	10,66	43,97	48	512	2110
Muretto 12"x 12"	11	10,66	42,12	30	320	1264



ALPES ROCK

Alpes

45 x 90 cm / 18"x 36"



Alpes Gris

45 x 90 cm
18"x 36"



Alpes Rock

45 x 90 cm
18"x 36"



Alpes Brun

45 x 90 cm
18"x 36"



Alpes Creme

45 x 90 cm
18"x 36"



Alpes	Pcs/Caja Pcs/Box	m ² /Caja m ² /Box	Peso/Caja (Kg) Weight/Box	Caja/Palet Box/Pallet	m ² /Palet m ² /Pallet	Peso/Palet (Kg) Weight/Pallet
	Pcs/Caja Pcs/Box	sq.ft./Caja sq.ft./Box	Peso/Caja Weight/Box(lb)	Caja/Palet Box/Pallet	sq.ft./Palet sq.ft./Pallet	Peso/Palet Weight/Pallet(lb)
	4	1,626	36,66	48	78,048	1760
	4	17,50	80,82	48	840	3879



ALPES GRIS

Alpes

45 x 90 cm / 18"x 36"



Alpes Gris

45 x 90 cm
18"x 36"



Alpes Brun

45 x 90 cm
18"x 36"



Alpes	Pcs/Caja Pcs/Box	m ² /Caja m ² /Box	Peso/Caja (Kg) Weight/Box	Caja/Palet Box/Pallet	m ² /Palet m ² /Pallet	Peso/Palet (Kg) Weight/Pallet
	Pcs/Caja Pcs/Box	sq.ft./Caja sq.ft./Box	Peso/Caja Weight/Box(lb)	Caja/Palet Box/Pallet	sq.ft./Palet sq.ft./Pallet	Peso/Palet Weight/Pallet(lb)
	4	1,626	36,66	48	78,048	1760
	4	17,50	80,82	48	840	3879



ALPES ROCK

Alpes

45 x 90 cm / 18"x 36"

MOSAIC

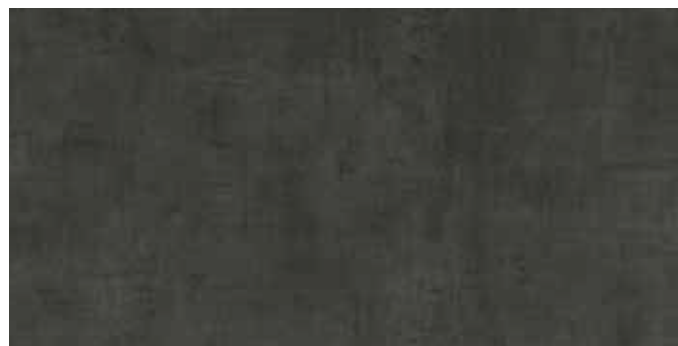

Alpes Rock

45 x 90 cm
18"x 36"



Alpes Creme

45 x 90 cm
18"x 36"

ESSENTIA



Alpes	Pcs/Caja Pcs/Box	m ² /Caja m ² /Box	Peso/Caja (Kg) Weight/Box	Caja/Palet Box/Pallet	m ² /Palet m ² /Pallet	Peso/Palet (Kg) Weight/Pallet
	Pcs/Caja Pcs/Box	sq.ft./Caja sq.ft./Box	Peso/Caja Weight/Box(lb)	Caja/Palet Box/Pallet	sq.ft./Palet sq.ft./Pallet	Peso/Palet Weight/Pallet(lb)
	4	1,626	36,66	48	78,048	1760
	4	17,50	80,82	48	840	3879

PORCELAIN



LOFT BONE

Loft

60 x 60 cm / 24"x 24"



Loft Bone

60 x 60 cm
24"x 24"



PAVIMENTO REVESTIMIENTO
WALL & FLOOR TILES



BRILLO
SHINY



DESTONIFICADO
SHADE



PORCELANICO
PORCELAIN



ESMALTADO
GLAZED



IMPRESION DIGITAL
DIGITAL PRINTING

Loft	Pcs/Caja Pcs/Box	m ² /Caja m ² /Box	Peso/Caja (Kg) Weight/Box	Caja/Palet Box/Pallet	m ² /Palet m ² /Pallet	Peso/Palet (Kg) Weight/Pallet
	Pcs/Caja Pcs/Box	sq.ft./Caja sq.ft./Box	Peso/Caja Weight/Box(lb)	Caja/Palet Box/Pallet	sq.ft./Palet sq.ft./Pallet	Peso/Palet Weight/Pallet(lb)
	4	1,440	33,23	30	43,2	997
	4	15,50	73,26	30	465	2198



LOFT MARFIL

Loft

60 x 60 cm / 24"x 24"



Loft Marfil

60 x 60 cm
24"x 24"



PAVIMENTO REVESTIMIENTO
WALL & FLOOR TILES



BRILLO
SHINY



DESTONIFICADO
SHADE



PORCELANICO
PORCELAIN



ESMALTADO
GLAZED



IMPRESION DIGITAL
DIGITAL PRINTING

Loft	Pcs/Caja Pcs/Box	m ² /Caja m ² /Box	Peso/Caja (Kg) Weight/Box	Caja/Palet Box/Pallet	m ² /Palet m ² /Pallet	Peso/Palet (Kg) Weight/Pallet
	4	1,440	33,23	30	43,2	997
Loft	Pcs/Caja Pcs/Box	sq.ft./Caja sq.ft./Box	Peso/Caja Weight/Box(lb)	Caja/Palet Box/Pallet	sq.ft./Palet sq.ft./Pallet	Peso/Palet Weight/Pallet(lb)
	4	15,50	73,26	30	465	2198



DOMUS BIANCO

Domus

5 x 5 - 30 x 60 - 60 x 60 cm / 2"x 2" - 12"x 24" - 24"x 24"



Domus Bianco 60 x 60 cm
24"x 24"



Domus Bianco 30 x 60 cm
12"x 24"



Domus Bianco 5x5
30 x 30 cm
12"x 12"



Domus Esagono 5x5
30 x 30 cm
12"x 12"



5 x 5
Esagono



30 x 60 cm
60 x 60 cm



Domus	Pcs/Caja Pcs/Box	m ² /Caja m ² /Box	Peso/Caja (Kg) Weight/Box	Caja/Palet Box/Pallet	m ² /Palet m ² /Pallet	Peso/Palet (Kg) Weight/Pallet
5 x 5	11	0,990	20,16	63	62,37	1270
Esagono	11	1,047	22,00	63	65,961	1386
30 x 60 cm	8	1,440	33,00	40	57,6	1320
60 x 60 cm	4	1,440	34,00	36	51,84	1224
	Pcs/Caja Pcs/Box	sq.ft./Caja sq.ft./Box	Peso/Caja Weight/Box(lb)	Caja/Palet Box/Pallet	sq.ft./Palet sq.ft./Pallet	Peso/Palet Weight/Pallet(lb)
2"x 2"	11	10,66	44,45	63	671	2800
Esagono	11	11,27	48,50	63	710	3056
12"x 24"	8	15,50	72,75	40	620	2910
24"x 24"	4	15,50	74,96	36	558	2698



DOMUS BIANCO

Domus

5 x 5 - 30 x 60 - 60 x 60 cm / 2"x 2" - 12"x 24" - 24"x 24"



Domus Bianco

60 x 60 cm
24"x 24"



FRANCO REVESTIMENTO
WALL & FLOOR TILES



BRILLO
SHINY



PULIDO
POLISHED



RECTIFICADO
RECTIFIED



PORCELANICO
PORCELAIN



ESMALTADO
GLAZED



IMPRESION DIGITAL
DIGITAL PRINTING

Domus	Pcs/Caja Pcs/Box	m ² /Caja m ² /Box	Peso/Caja (Kg) Weight/Box	Caja/Palet Box/Pallet	m ² /Palet m ² /Pallet	Peso/Palet (Kg) Weight/Pallet
60 x 60 cm	4	1,440	34,00	36	51,84	1224
	Pcs/Caja Pcs/Box	sq.ft./Caja sq.ft./Box	Peso/Caja Weight/Box(lb)	Caja/Palet Box/Pallet	sq.ft./Palet sq.ft./Pallet	Peso/Palet Weight/Pallet(lb)
24"x 24"	4	15,50	74,96	36	558	2698



MONTBLANC
DOMUS BLANCO

Montblanc

5 x 5 - 30 x 60 - 60 x 60 cm / 2"x 2" - 12"x 24" - 24"x 24"



Montblanc 60 x 60 cm
24" x 24"

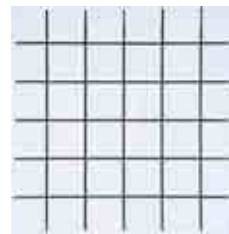

Montblanc 5x5
30 x 30 cm
12" x 12"

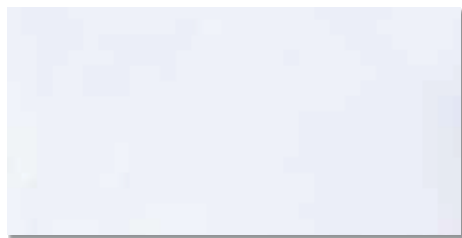

Montblanc 30 x 60 cm
12" x 24"



5 x 5



30 x 60 cm
60 x 60 cm



Montblanc	Pcs/Caja Pcs/Box	m ² /Caja m ² /Box	Peso/Caja (Kg) Weight/Box	Caja/Palet Box/Pallet	m ² /Palet m ² /Pallet	Peso/Palet (Kg) Weight/Pallet
5 x 5	11	0,990	20,90	63	62,37	1317
30 x 60 cm	8	1,440	32,80	40	57,6	1312
60 x 60 cm	4	1,440	32,80	32	46,08	1050
	Pcs/Caja Pcs/Box	sq.ft./Caja sq.ft./Box	Peso/Caja Weight/Box(lb)	Caja/Palet Box/Pallet	sq.ft./Palet sq.ft./Pallet	Peso/Palet Weight/Pallet(lb)
2" x 2"	11	10,66	46,08	63	671	2903
12" x 24"	8	15,50	72,31	40	620	2892
24" x 24"	4	15,50	72,31	32	496	2314



TEIDE



Teide

60 x 60 cm / 24"x 24"



Teide

60 x 60 cm
24"x 24"



Teide	Pcs/Caja Pcs/Box	m ² /Caja m ² /Box	Peso/Caja (Kg) Weight/Box	Caja/Palet Box/Pallet	m ² /Palet m ² /Pallet	Peso/Palet (Kg) Weight/Pallet
	Pcs/Caja Pcs/Box	sq.ft./Caja sq.ft./Box	Peso/Caja Weight/Box(lb)	Caja/Palet Box/Pallet	sq.ft./Palet sq.ft./Pallet	Peso/Palet Weight/Pallet(lb)
	4	1,440	33,71	36	51,84	1214
	4	15,50	74,32	36	558	2675



ARTIC
KENYA

Teknia

5 x 5 - 30 x 30 - 30 x 60 - 60 x 60 cm / 2"x 2" - 12"x 12" - 12"x 24" - 24"x 24"

MOSAIC

ESSENTIA

PORCELAIN

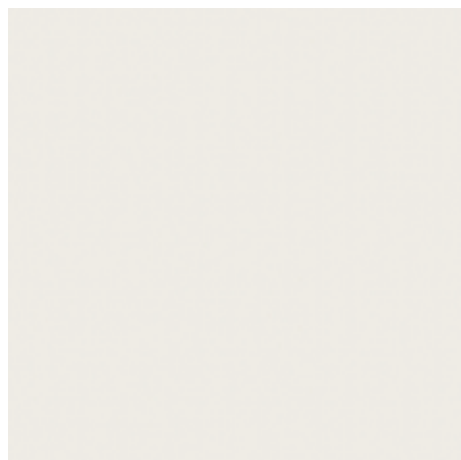

Artic 60 x 60 cm
24"x 24"

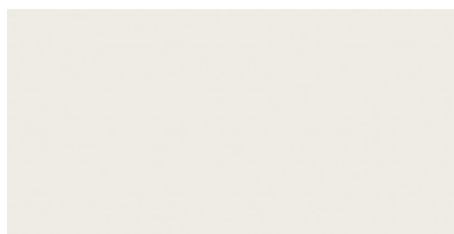

Artic 30 x 60 cm
12"x 24"

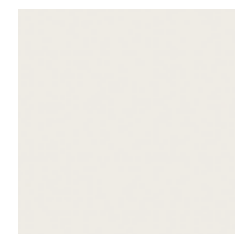

Artic 30 x 30 cm
12"x 12"



Artic 5 x 5
30 x 30 cm
12"x 12"

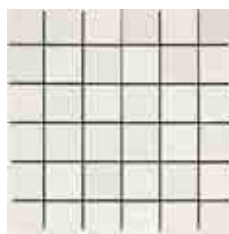

Artic 3D 5 x 5
30 x 30 cm
12"x 12"



Quarz Artic 3D
30 x 30 cm
12"x 12"

5 x 5



Quartz 3D
5 x 5 3D



30 x 30 cm
30 x 60 cm
60 x 60 cm



Teknia	Pcs/Caja Pcs/Box	m ² /Caja m ² /Box	Peso/Caja (Kg) Weight/Box	Caja/Palet Box/Pallet	m ² /Palet m ² /Pallet	Peso/Palet (Kg) Weight/Pallet
5 x 5	11	0,990	21,00	63	62,37	1323
Quartz 30 x 30 cm	11	0,990	21,00	63	62,37	1323
30 x 30 cm	11	0,990	21,00	48	47,52	1008
30 x 60 cm	8	1,440	23,75	32	46,08	760
60 x 60 cm	4	1,440	23,75	32	46,08	760
	Pcs/Caja Pcs/Box	sq.ft./Caja sq.ft./Box	Peso/Caja Weight/Box(lb)	Caja/Palet Box/Pallet	sq.ft./Palet sq.ft./Pallet	Peso/Palet Weight/Pallet(lb)
2"x 2"	11	10,66	46,30	63	671	2917
Quartz 12"x 12"	11	10,66	46,30	63	671	2917
12"x 12"	11	10,66	46,30	48	512	2222
12"x 24"	8	15,50	52,36	32	496	1676
24"x 24"	4	15,50	52,36	32	496	1676



KENYA

Teknia

5 x 5 - 30 x 30 - 30 x 60 - 60 x 60 cm / 2"x 2" - 12"x 12" - 12"x 24" - 24"x 24"

MOSAIC

ESSENTIA

PORCELAIN



Kenya 60 x 60 cm
24"x 24"



Kenya 30 x 60 cm
12"x 24"



Kenya 30 x 30 cm
12"x 12"



Kenya 5 x 5
30 x 30 cm
12"x 12"



Kenya 3D 5 x 5
30 x 30 cm
12"x 12"



Quarz Kenya 3D
30 x 30 cm
12"x 12"

5 x 5



Quartz 3D
5 x 5 3D



30 x 30 cm
30 x 60 cm
60 x 60 cm



Teknia	Pcs/Caja Pcs/Box	m ² /Caja m ² /Box	Peso/Caja (Kg) Weight/Box	Caja/Palet Box/Pallet	m ² /Palet m ² /Pallet	Peso/Palet (Kg) Weight/Pallet
5 x 5	11	0,990	21,00	63	62,37	1323
Quartz 30 x 30 cm	11	0,990	21,00	63	62,37	1323
30 x 30 cm	11	0,990	21,00	48	47,52	1008
30 x 60 cm	8	1,440	23,75	32	46,08	760
60 x 60 cm	4	1,440	23,75	32	46,08	760
	Pcs/Caja Pcs/Box	sq.ft./Caja sq.ft./Box	Peso/Caja Weight/Box(lb)	Caja/Palet Box/Pallet	sq.ft./Palet sq.ft./Pallet	Peso/Palet Weight/Pallet(lb)
2"x 2"	11	10,66	46,30	63	671	2917
Quartz 12"x 12"	11	10,66	46,30	63	671	2917
12"x 12"	11	10,66	46,30	48	512	2222
12"x 24"	8	15,50	52,36	32	496	1676
24"x 24"	4	15,50	52,36	32	496	1676



SIMAT

Marmi

50 x 50 cm / 20"x 20"

MOSAIC

ESSENTIA

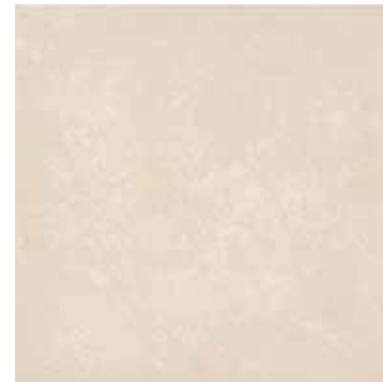

Simat

50 x 50 cm
20"x 20"

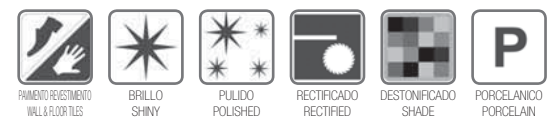

PAVIMENTO REVESTIMIENTO
WALL & FLOOR TILES

BRILLO
SHINY

PULIDO
POLISHED

RECTIFICADO
RECTIFIED

DESTONIFICADO
SHADE

P
PORCELANICO
PORCELAIN

Marmi	Pcs/Caja Pcs/Box	m ² /Caja m ² /Box	Peso/Caja (Kg) Weight/Box	Caja/Palet Box/Pallet	m ² /Palet m ² /Pallet	Peso/Palet (Kg) Weight/Pallet
	Pcs/Caja Pcs/Box	sq.ft./Caja sq.ft./Box	Peso/Caja Weight/Box(lb)	Caja/Palet Box/Pallet	sq.ft./Palet sq.ft./Pallet	Peso/Palet Weight/Pallet(lb)
	7	1,750	29,00	36	63	1044
	7	18,84	63,93	36	678	2302

PORCELAIN



CAPRI

Layer

30 x 60 - 60 x 60 - 80 x 80 cm / 12"x 24" - 24"x 24" - 32"x 32"



Capri

80 x 80 cm
32"x 32"

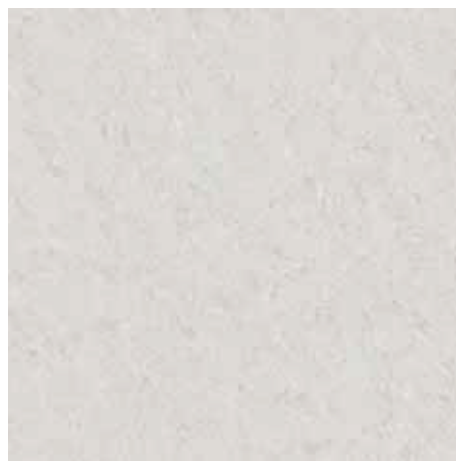

Capri

60 x 60 cm
24"x 24"

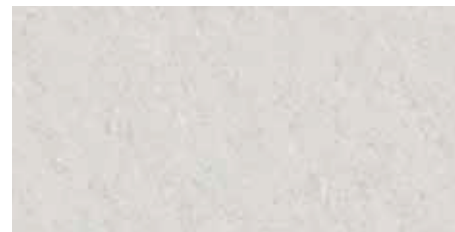

Capri

30 x 60 cm
12"x 24"



FRANCO REVESTIMENTO
WALL & FLOOR TILES



BRILLO
SHINY



PULIDO
POLISHED



RECTIFICADO
RECTIFIED



DESTONIFICADO
SHADE



PORCELANICO
PORCELAIN

Capri	Pcs/Caja Pcs/Box	m ² /Caja m ² /Box	Peso/Caja (Kg) Weight/Box	Caja/Palet Box/Pallet	m ² /Palet m ² /Pallet	Peso/Palet (Kg) Weight/Pallet
	Pcs/Caja Pcs/Box	sq.ft./Caja sq.ft./Box	Peso/Caja Weight/Box(lb)	Caja/Palet Box/Pallet	sq.ft./Palet sq.ft./Pallet	Peso/Palet Weight/Pallet(lb)
30 x 60 cm	8	1,440	30,00	40	57,6	1200
60 x 60 cm	4	1,440	30,00	40	57,6	1200
80 x 80 cm	3	1,920	45,00	28	53,76	1260
12"x 24"	8	15,50	66,14	40	620	2646
24"x 24"	4	15,50	66,14	40	620	2646
32"x 32"	3	20,67	99,21	28	579	2778



MÓDENA

Layer

80 x 80 cm / 32"x 32"

MOSAIC

ESSENTIA



Módena

80 x 80 cm
32"x 32"



PAVIMENTO REVESTIMIENTO
WALL & FLOOR TILES



BRILLO
SHINY



PULIDO
POLISHED



RECTIFICADO
RECTIFIED



DESTONIFICADO
SHADE



P
PORCELÁNICO
PORCELAIN

Módena	Pcs/Caja Pcs/Box	m ² /Caja m ² /Box	Peso/Caja (Kg) Weight/Box	Caja/Palet Box/Pallet	m ² /Palet m ² /Pallet	Peso/Palet (Kg) Weight/Pallet
	Pcs/Caja Pcs/Box	sq.ft./Caja sq.ft./Box	Peso/Caja Weight/Box(lb)	Caja/Palet Box/Pallet	sq.ft./Palet sq.ft./Pallet	Peso/Palet Weight/Pallet(lb)
	4	1,440	30,00	40	57,6	1200
	4	15,50	66,14	40	620	2646

PORCELAIN



ACQUA

Acqua



Acqua
Acc. dosific. jabón/soap dispenser



Acqua
Acc. portavasos/tumbler holder



Acqua
Acc. toallero aro/towel ring



Acqua
Acc. portarrollos/paper holder



Acqua
Acc. percha doble/double robe hook

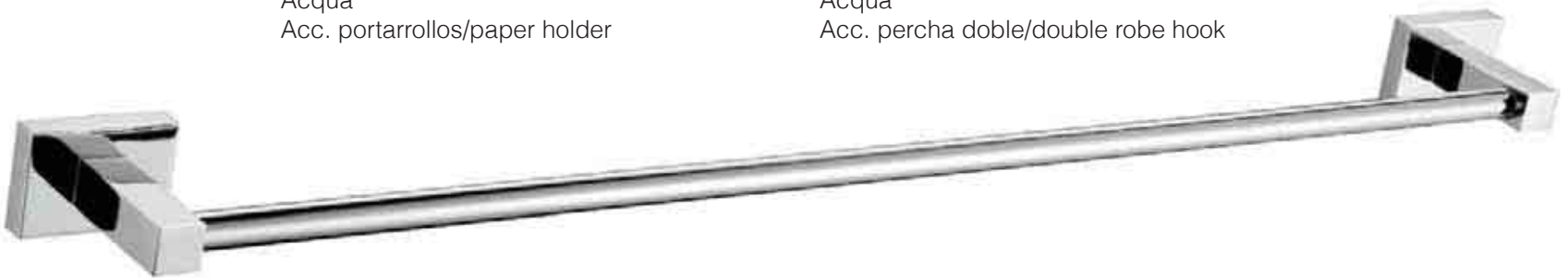

Acqua
Acc. toallero barra/towel bar

DESCRIPCIÓN	Dimensiones Pieza cm	Pcs/Palet Pzs/Pallet	Peso/Pz Weight/Pz (Kg)	Peso/Palet Weight/Pallet (Kg)	Peso/Pz Weight/Pz (lb)	Peso/Palet Weight/Pallet (lb)
Acc.Percha Doble / Double Robe Hook - ACQUA	5 x 3,5 x 5,5	2100	0,129	358	0,284	789
Acc. Portavasos / Tumbler Holder - ACQUA	12,9 x 9,5 x 8,8	750	0,342	315	0,754	694
Acc. Dosific. Jabón / Soap Dispenser - ACQUA	12 x 14,5 x 8,8	500	0,378	230	0,833	507
Acc. Toallero Aro / Towel Ring - ACQUA	15,5 c 16,5 x 6,5	200	0,141	46	0,311	101
Acc. Portarrollos / Paper Holder - ACQUA	12 x 13 x 6,5	400	0,230	136	0,507	300
Acc. Toallero Barra / Towel Bar - ACQUA	63,5 x 3,5 x 6,5	350	0,265	140	0,584	309



LOVE

ACQUA BLUE

Acqua

Tuning Brown



Tuning Orange



Tuning Red



Tuning Green



Tuning Blue



Tuning Black



Portarrollos Tuning Blue



Portavasos/Toallero barra Tuning Black



Dosificador/Toallero aro Tuning Orange



Toallero aro/Dosificador Tuning Red



Percha doble Tuning Green



Toallero barra Tuning Brown

Pack 7 unidades



Tuning	Dimensiones Pieza cm	Pza/Pack
	4,5 x 3,0 x 0,5	7

Los complementos intercambiables Tuning decoran la serie de accesorios de baño Acqua con una gama de 6 colores diferentes. El pack indivisible incluye 7 piezas de un mismo color, las necesarias para decorar un set completo de accesorios de baño Acqua.

The Tuning interchangeable complements decorate the Acqua bathroom accessories with a range of 6 different colors. The indivisible pack includes 7 pieces of the same color, necessary to decorate a complete set of Acqua bathroom accessories.

Ensayos realizados y especificaciones técnicas

Test done and technical specifications

ENSAYOS REALIZADOS POR
TESTS DONE BY



- UNE-EN-ISO 10545-2 DETERMINACIÓN DE LAS DIMENSIONES (LONGITUD y PLANITUD DE SUPERFICIE)
SIZE DETERMINATION (LENGTH AND SURFACE PLANARITY)
- UNE-EN-ISO 10545-3 DETERMINACIÓN DE LA ABSORCIÓN DE AGUA
WATER ABSORPTION TEST
- UNE-EN-ISO 10545-4 RESISTENCIA A LA FLEXIÓN Y CARGA DE ROTURA
FLEXURAL STRENGTH AND BREAKAGE LOAD
- UNE-EN-ISO 10545-6 DETERMINACIÓN DE LA RESISTENCIA A LA ABRASIÓN PROFUNDA. BALDOSAS NO ESMALTADAS
DEEP ABRASION RESISTANCE TEST. UNGLAZED TILES
- UNE 67-101-92=EN-101 DETERMINACIÓN DE LA DUREZA AL RAYADO DE LA SUPERFICIE SEGÚN MOHS.
MOHS TEST FOR SURFACE SCRATCHED HARDNESS

Especificaciones técnicas del Gres Porcelánico

Porcelain Floor Tile technical specifications

Norma Standard	Descripción Description	Mínimo exigido Grupo B1a B1a Group minimum demanded	Especificación Intermatex Intermatex specification
ISO 10545-2	Longitud y anchura Length and width	max. 0.6%	<0.1%
ISO 10545-2	Planitud de superficie Surface planarity	max. 0.5%	<0.1%
ISO 10545-3	Absorción de agua Water absorption	max. 0.5%	<0.2%
ISO 10545-4	Resistencia a la Flexión y carga de rotura Flexurat strength and breakage load	>900N	>1100N
ISO 10545-6	Abrasión profunda Deep abrasion	max. 175 mm ³	<115 mm ³
EN-101.1191	Dureza al rayado según Mohs Scratched hardness Mohs index	no exigible (Pulido) not demanded (Polished) min 4-6 (Esmaltado / Glazed)	MOHS 4 MOHS 5-9
UNE-ENV 12633-2003 Anexo A	Resistencia al deslizamiento (Péndulo)		A consultar según modelo To enquire according to the models
DIN 51130.2010 Apdo. 5	Determinación de ángulo crítico del deslizamiento (Rampa)		A consultar según modelo To enquire according to the models

Promotion | Displays

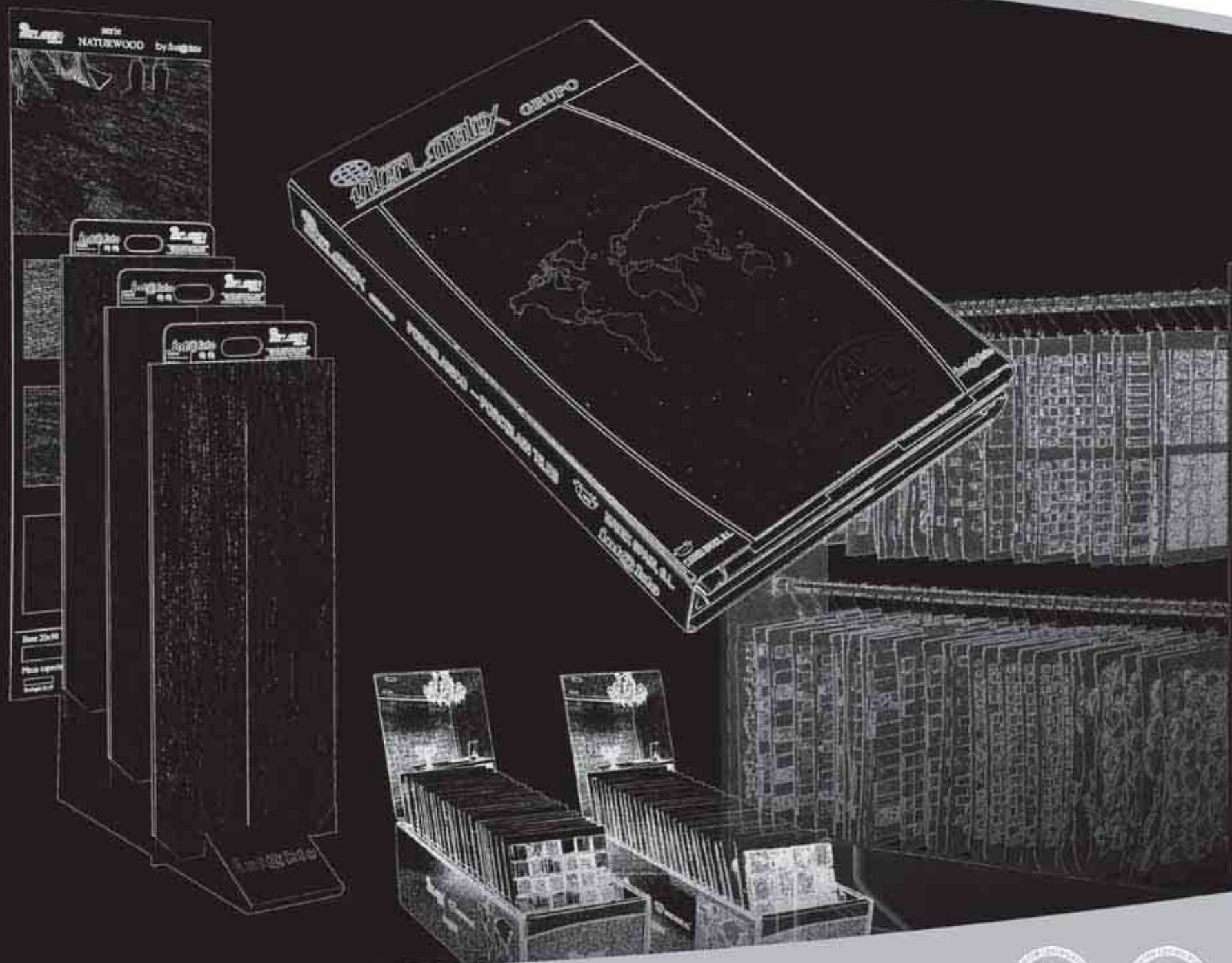

CERTIFIED COMPANIES ISO 9001- ISO 14001



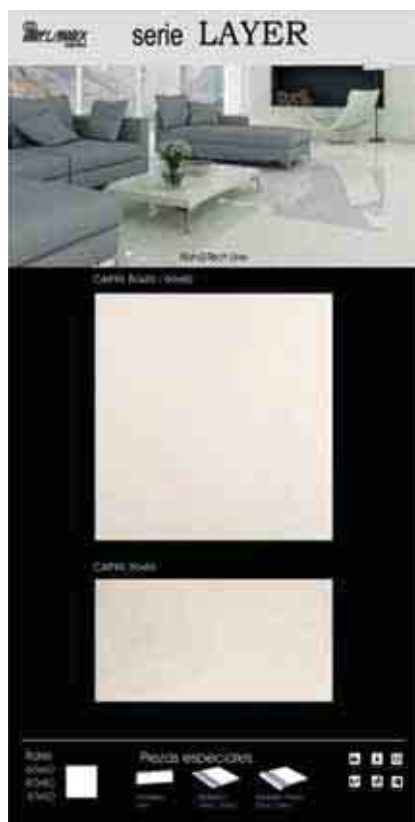

Panel Serie LAYER CAPRI



Panel Serie LAYER CAPRI



Panel Serie LAYER MÓDENA



Panel Serie TEKNIA



Panel Serie STRATO



Panel Serie ALPES



Panel Serie CEMENTI



Panel Serie LOFT

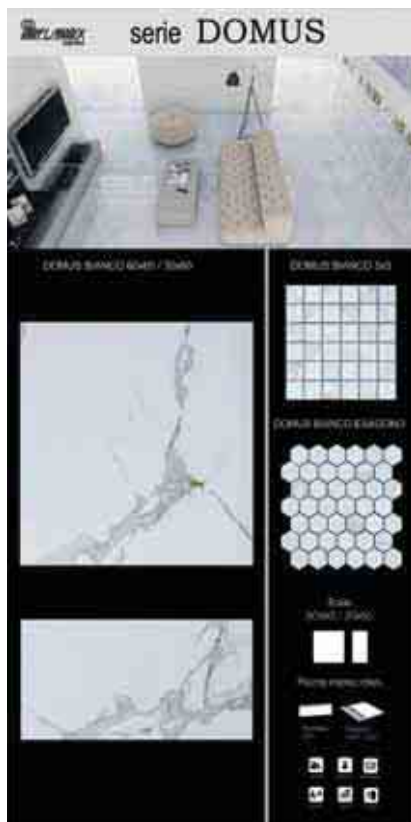

Panel Serie DOMUS



Panel Serie LUX



Panel Serie PETRA



Expositor SET PORCELÁNICO COMPLETO



Expositor CUNA CEMENTI

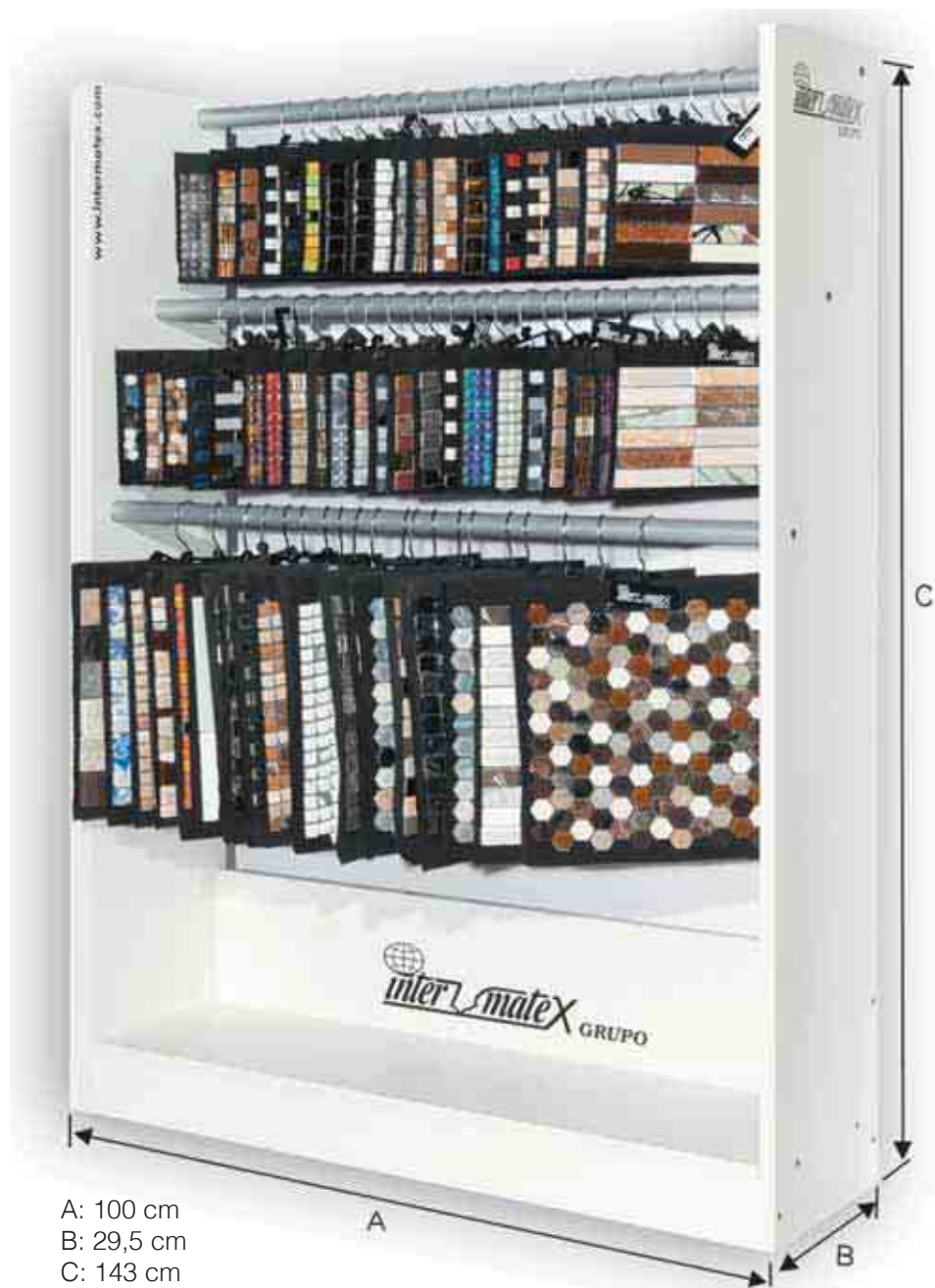

A: 100 cm
 B: 29,5 cm
 C: 143 cm

Expositor MALLAS 3 BAR (BLANCO 100)



A: 60 cm
 B: 29,5 cm
 C: 143 cm

Expositor MALLAS 2 BAR (BLANCO 60)

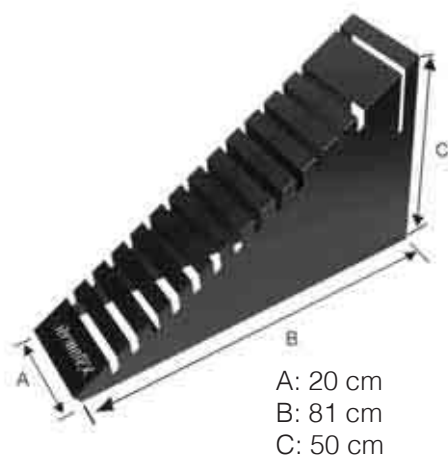

A: 20 cm
 B: 81 cm
 C: 50 cm



A: 20 cm
 B: 81 cm
 C: 50 cm

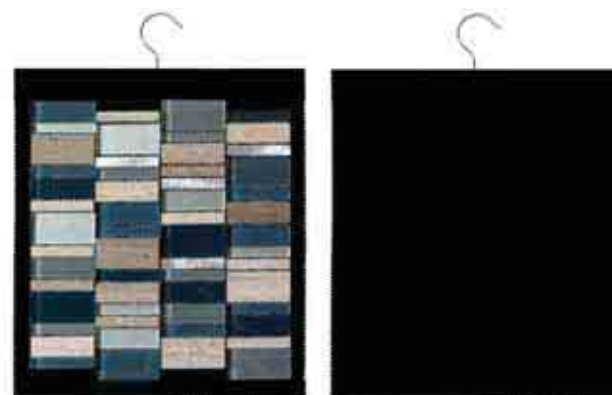

PERCHA INTEGRAL



Expositor MALLAS ROJO 60 ESSENTIA



DISPLAY TORRE



Expositor MALLAS ON DESK (2 pcs SET)



Expositor SOBREMESA 4 BAR

MOSAICO / MOSAIC

Preparación de la superficie:

La superficie debe estar limpia, compacta, perfectamente plana y libre de suciedad y grietas.

Hay que igualar todas las áreas irregulares de la superficie, es posible que se necesite una capa para nivelar y hacer que la superficie sea plana.

Asegúrese de que la superficie esté seca, con un máximo de 3% de humedad contenida.

No instale los mosaicos directamente sobre contrachapado o paneles de yeso

Colocación:

Antes de iniciar la instalación inspeccione todas las mallas de mosaico y asegúrese que el material está en buenas condiciones y sin defectos. Establecer directrices mientras se alicata ayudarán a que el producto quede alineado.

El tamaño de la llana dentada depende del mosaico, cuanto más delgados los mosaicos más pequeña la llana.

Recomendamos adhesivo de alto rendimiento (especial para mosaicos y porcelánico).

Asegúrese de aplicar sólo adhesivo al área que puede chapar en 15 minutos, ya que se seca muy rápido.

Después de pegar los mosaicos, utilizar una llana de goma para presionar los mosaicos para garantizar una perfecta adhesión. Asegúrese de que la distancia entre diferentes mallas es la misma que la que existe entre las piezas en la misma malla.

Adhesivo requiere por lo menos 24 horas para secar.

Manipular los mosaicos cuidadosamente ya que contienen elementos frágiles como el vidrio, espejo, acero, aluminio, travertino, mármol, resina, porcelánico, nácar, cuarzo, etc.

Rejuntado:

Antes de aplicar el rejunte asegúrese de que todas las piezas están perfectamente limpias y libres de residuos y polvo.

Rejunte no arenoso (no abrasivo) es el rejunte recomendado para ser utilizado para el mosaico debido a las pequeñas juntas. Evite utilizar rejunte arenoso, ya que puede rayar los algunos materiales como el vidrio, el acero inoxidable, la piedra pulida, etc

Usando una llana de goma aplicar el rejunte en los mosaicos. Aplíquelo en dirección vertical y horizontal para esparcir el rejunte. Aplique un poco de presión para asegurarse de que todas las juntas están bien rellenas.

Mientras el rejunte está todavía fresco, deslice en diagonal con el borde largo de la llana de goma para eliminar el exceso de rejunte y luego limpie con una esponja húmeda.

Productos abrasivos y alcalinos no deben ser utilizados para eliminar los residuos.

Limpieza:

Para la limpieza se necesita: detergentes neutros o limpiacristales y un paño suave y limpio (para evitar rayar).

Se recomienda aplicar un tratamiento de mármol de mosaicos de vidrio, al menos, una vez al año.

Notas:

Todos los mosaicos están hechos a mano, por lo que pequeñas variaciones en color son habituales. Se recomienda comprobar las piezas antes de la colocación

Al cortar mosaicos con una sierra de agua, poner un azulejo o un trozo de plástico duro debajo en la bandeja de corte. Esto es necesario para evitar que el mosaico caiga dentro de la apertura de disco de corte, y así ser capaz de hacer un buen corte recto.

Substrate preparation:

The substrates need to be clean, compact, perfectly flat and free of dirt and cracks. Fix all the uneven areas of the surface, leveling compound might be needed to make the surface flat.

Ensure the surface is dry, with a maximum of 3% moisture content.

Do not install the mosaic tiles directly over plywood or drywall

Laying mosaic:

Before starting the installation inspect all mosaic sheets and make sure material is in good conditions and no defects. Guidelines while laying will help the layout to be straight.

The size of the v-notch trowel depends on the mosaic tiles, thinner the mosaics the smaller the trowel.

We recommend high-performance adhesive for glass mosaics and porcelain.

Make sure to apply only enough adhesive to areas that you can tile within 15min, because it dries very quick

After you lay down the mosaics use a grout float to press the mosaics to guarantee perfect adhesion. Ensure the distance between different meshes is the same as the one between the pieces in the same mesh

Adhesive requires at least 24hours to dry.

Treat the mosaics carefully as they contain fragile elements such as glass, mirror, steel, aluminium, travertine, marble, resin, porcelain, mother of pearl, quartz, etc.

Grouting:

Before applying grouts make sure all pieces are perfectly clean and free of residues and dust.

Not-sanded grout is the recommended grout to be used for mosaic sheets due to the small grout joint. Never use sanded grout as it may scratch some materials like glass, stainless steel, polished stone, etc.

Using a grout float apply the grout on the mosaics. Use vertical and horizontal stroke to spread the grout. Apply a little pressure to make sure that all the joints are well filled.

While the grout is still fresh, stroke diagonally with the long edge of the grout float to remove excess grout and then wipe it with wet sponge the clean

Abrasive and alkaline products must not be used to remove residues.

Cleaning:

For cleaning you need: neutral detergents or glass cleaner and a clean soft cloth (to avoid scratches).

It is recommended to apply a marble treatment to glass mosaics at least once a year.

Notes:

All our mosaics are handmade, so small variations in shade are usual. It is recommended to check the pieces before laying

When cutting mosaics with a wet saw, put a tile or a piece of hard plastic down on the cutting tray.

This is necessary to keep the mosaic away from falling in the wide opening of the blade channel tray to be able to make a good straight cut.

PIEDRA NATURAL / NATURAL STONE

La piedra tiene variaciones de color y diseño propios de un producto natural. Con la intención de respetar éstas características únicas, las piezas deben ser colocadas siguiendo algunas recomendaciones.

PREVIO A LA INSTALACIÓN

La superficie a ser revestida debe estar adecuadamente aplanada y limpia, pero sobre todo bien nivelada.

Es recomendable presentar anticipadamente las piezas en el lugar de colocación para poder decidir la correcta distribución de los tonos que estas tienen y visualizar su efecto final antes de hacer el trabajo de instalación. Se recomienda abrir varias cajas y sacar aleatoriamente las piezas que irán colocándose. Preparar la distribución de las piezas para evitar las posibles diferencias de calibre.

ADHESIVOS DE FIJACIÓN

Preparación de los soportes

En general los soportes cementosos deben estar limpios de polvo, aceites y grasas, secos y sin restos de humedad, exentos de restos de suciedad como residuos de cemento, cal o pinturas que deberán retirarse completamente.

Adhesivos recomendados

La colocación se debe realizar con adhesivos Tipo C2, tanto para exterior como para interior, cuya característica principal es su elevada adherencia y elasticidad, en cualquier caso recomendamos leer ficha técnica del fabricante antes de uso, donde se detallan modo de empleo y dosificación .

Se aconseja adhesivos que permitan la colocación de una capa gruesa para que absorba las posibles diferencias de la Piedra Natural.

INSTALACIÓN

El nivel de la primera pieza en colocarse es el que marcará el espesor de la capa del mortero que deberemos mantener para el resto de las piezas.

Es obligatorio el uso de la llana dentada para que la superficie total a trabajar este cubierta de pegamento y no se generen vacíos que posteriormente permitan que se rompan las esquinas de las piezas, a continuación de inserta la piedra sobre el lecho adhesivo y se presiona con un mazo de goma (importante no golpear).

LIMPIEZA Y MANTENIMIENTO

Limpieza de obra

Después de la colocación es fundamental realizar una buena limpieza para eliminar residuos de adhesivo, residuos superficiales del material.

Si se desea proteger la piedra natural contra las manchas se recomienda un sellante específico para la Piedra Natural.

Mantenimiento

Para un buen mantenimiento se aconseja el empleo de un detergente neutro de alto poder limpiador.

En los casos de suciedad orgánica intensa y acumulada en el tiempo, grasas, etc., se aconseja la utilización de un detergente de tipo desengrasante.

Para la aplicación de los distintos detergentes se recomienda aplicarlo con un pulverizador.

Para la limpieza habitual del polvo recomendamos la utilización de un plumero o similar.

The stone has the variations of colour and design typical of a natural product. With the intention to respect these unique features, pieces should be placed following some recommendations.

PRIOR TO INSTALLATION

The surface to be covered must be adequately flattened and clean, but mainly leveled. It is recommended to present the pieces in advance in the place of installation to decide the correct distribution of tones that these pieces have and to display their final effect before doing the installation work. It is recommended to open several boxes and randomly install the pieces. Prepare the distribution of parts to avoid possible differences in caliber.

FIXING ADHESIVES

Preparation of substrates

In general cementitious surfaces must be clean of dust, oils and fats, dry and free of moisture, free of debris as residues of cement, lime or paint.

Recommended adhesives

The placement should be done with Type C2 adhesives for both exterior and interior, whose main characteristic is its high adhesion and elasticity, in any case we recommend reading technical specifications of the adhesive manufacturer before use, where instructions for use and dosage are described.

Adhesives that allow placing a thick layer to absorb possible differences of Natural Stone advised.

INSTALLATION

The level of the first piece is placed to mark the thickness of the layer of mortar that we will keep for the rest of the pieces.

It is necessary to use a notched trowel so the working surface is completely covered with glue and gaps are not generated that subsequently allow the corners of the pieces to break. Then to insert the stone into the adhesive bed and pressed with a rubber hammer (important not to hit).

CLEANING AND MAINTENANCE

Cleaning the job

After installation is essential to make a good cleaning to remove adhesive residues, surface residues of material.

If you want to protect the natural stone against stains a specific sealant for natural stone is recommended.

Maintenance

For good maintenance using a neutral detergent high cleaning power it is advised. In cases of intense and organic dirt accumulated over time, fats, etc., using a degreasing detergent type it is recommended.

For the application of various detergents is recommended to apply with a sprayer. For regular cleaning of dust we recommend using a duster or similar.







Todas las dimensiones que figuran en éste catálogo son Nominales. Si usted desea saber las dimensiones reales de fabricación, consulte con nuestro departamento técnico.

All dimensions given in this catalogue are Nominal. Please contact our technical department, should you need to know the real manufactured dimensions.

Los colores de las piezas que aparecen en éste catálogo son orientativos.

Colors of pieces that appear in this catalogue are approximated.

Intermatex se reserva el derecho a anular o modificar el diseño de cualquiera de los modelos que aparecen en éste catálogo.

Intermatex reserves the right to modify or alter the design in any or all of the models here enclosed.

Porcelánico Mosaico Piedra Porcellanato Mosaico Piet
Porcelain Mosaik Stein Керамогранит Мозаика Каме
Grés cérame Mosaïque Pierre Porcelain Mosaik Stein K
Porcelain Mosaic Stone Grés cérame Mosaïque Pierre
Porcelánico Mosaico Piedra Porcellanato Mosaico Piet
Керамогранит Мозаика Камень Porcelánico Mosaico Pi
Porcelain Mosaik Stein Керамогранит Мозаика Камень
Porcelain Mosaic Stone Grés cérame Mosaïque Pierre
Piedra Porcellanato Mosaico Pietra Porcelain Mosaic St
Porcelánico Mosaico Piedra Porcellanato Mosaico Piet
Porcelain Mosaik Stein Керамогранит Мозаика Каме



CERTIFIED COMPANIES ISO 9001- ISO 14001



E-MAIL Info@intermatex.com

Http:// www.intermatex.com

Carretera Villarreal - Onda, Km. 3 | Apdo. Correos 242

12540 Villarreal (Castellón) - SPAIN

Tel. +34 964 50 53 30 | Fax +34 964 53 66 10